



University
of Glasgow

Douglas, R., van Veggel, A.A., Cunningham, L., Haughian, K., Hough, J., and Rowan, S. (2014) Cryogenic and room temperature strength of sapphire jointed by hydroxide-catalysis bonding. *Classical and Quantum Gravity*, 31 (4). Art. 045001. ISSN 0264-9381

Copyright © 2014 The Authors.

<http://eprints.gla.ac.uk/91897/>

Deposited on: 26 February 2014

Enlighten – Research publications by members of the University of
Glasgow <http://eprints.gla.ac.uk>

Cryogenic and room temperature strength of sapphire jointed by hydroxide-catalysis bonding

R Douglas, A A van Veggel, L Cunningham, K Haughian, J Hough and S Rowan

SUPA, School of Physics and Astronomy, University of Glasgow, Glasgow, G12 8QQ, UK

E-mail: r.douglas.1@research.gla.ac.uk

Received 17 November 2013, revised 19 December 2013

Accepted for publication 20 December 2013

Published 22 January 2014

Abstract

Hydroxide-catalysis bonding is a precision technique used for jointing components in opto-mechanical systems and has been implemented in the construction of quasi-monolithic silica suspensions in gravitational wave detectors. Future detectors are likely to operate at cryogenic temperatures which will lead to a change in test mass and suspension material. One candidate material is mono-crystalline sapphire. Here results are presented showing the influence of various bonding solutions on the strength of the hydroxide-catalysis bonds formed between sapphire samples, measured both at room temperature and at 77 K, and it is demonstrated that sodium silicate solution is the most promising in terms of strength, producing bonds with a mean strength of 63 MPa. In addition the results show that the strengths of bonds were undiminished when tested at cryogenic temperatures.

Keywords: gravitational waves, sapphire, hydroxide-catalysis bonding, cryogenic

PACS number: 04.30.-w

(Some figures may appear in colour only in the online journal)



Content from this work may be used under the terms of the [Creative Commons Attribution 3.0 licence](https://creativecommons.org/licenses/by/3.0/). Any further distribution of this work must maintain attribution to the author(s) and the title of the work, journal citation and DOI.

1. Introduction

Hydroxide-catalysis bonding (sometimes called silicate bonding) is a precision optical jointing technique originally developed and patented by Gwo for use in the Gravity Probe B telescope [1, 2]. This technology has been implemented in the construction of quasi-monolithic suspensions in laser interferometric gravitational wave detectors [3–5]. It allows precision bonding of optical components, creating optically clear bonds with strengths that can be similar to the bulk material [6]. This is generally achieved at room temperature by applying an aqueous solution containing hydroxide ions to at least one of the two bonding surfaces and by placing the surfaces sufficiently close to each other to form a chemical bond between them.

Laser interferometric gravitational wave detectors utilize laser interferometry to detect small changes in the separation of freely suspended mirrors (or test masses) as a result of gravitational waves. Initial searches for gravitational waves have been completed by a network of such detectors, including the US LIGO detectors [7], the French–Italian Virgo detector [8], the German–UK GEO600 detector [9] and the Japanese TAMA300 facility [10].

In the field of gravitational wave detection the technique of hydroxide-catalysis bonding was first used in jointing fused silica prisms or ‘ears’ to the test masses in the GEO 600 detector to create a quasi-monolithic suspension system [3]. These ears were bonded to the side of the test masses to provide welding points for fused silica fibres [11]. Similar quasi-monolithic suspensions are currently being installed in upgrades to the LIGO [12] and Virgo [13] detectors; advanced LIGO and advanced Virgo respectively.

Plans for the construction of the Japanese KAGRA detector are also underway [14]. This will initially run at room temperature but will later be upgraded to run at cryogenic temperatures. Third generation detectors, such as the Einstein telescope (ET) may also run at cryogenic temperatures [15]. This will lead to the requirement for alternative materials, as a peak in the mechanical loss profile of fused silica at 40 K suggests that, in terms of thermal noise, it may not be a favourable choice of material for low temperature operation [16]. Both silicon and sapphire have more desirable thermo-mechanical properties in the cryogenic regime and as such are very promising candidates for use in ET and KAGRA respectively [16–18]. Silicon has a higher thermal conductivity than sapphire but sapphire has the more immediate advantage of being optically transparent at 1064 nm. Hydroxide-catalysis bonding may then be useful for constructing sapphire suspensions in a manner similar to the fused silica suspensions constructed for other detectors, making characterization of the properties of sapphire jointed by hydroxide-catalysis bonding an important area of interest.

2. Hydroxide-catalysis bonding

Hydroxide-catalysis bonding allows precision bonding of optical components, creating optically clear bonds that are very thin, and therefore capable of introducing relatively little excess thermal noise. It can be used to joint materials whose surfaces can be hydrated and subsequently dehydrated in the presence of a hydroxide catalyst. This is generally achieved at room temperature by applying hydroxide ions in an aqueous solution to at least one of the two bonding surfaces and by placing the surfaces sufficiently close to each other to form polymer-like chains, and thus a chemical bond, between them [19]. In the case of sapphire either siloxane chains, or aluminate chains, or both may form—depending on the solution used. NaOH, KOH, NH₄OH and Na₂SiO₃ are all suitable when used in an aqueous solution and have been used successfully in the past [2], with NaOH and KOH shown to be particularly effective [20]. Previously the technique has been used for bonding fused silica; for example in the quasi-monolithic GEO 600 suspensions, and silicon carbide [21]. It has also been used

in jointing silica to low expansion glass for the optical benches of a type considered for use in the planned space-based detector, eLISA [22]. It is currently under development at Glasgow for bonding silicon [23, 24] and crystalline sapphire following initial investigations by Dari *et al* [25] and Suzuki *et al* [26].

For reliable bond formation when using the hydroxide-catalysis bonding technique the bond surfaces should be flat: bonds where surfaces have an overall peak-to-peak flatness of $\leq \lambda/10$ where $\lambda = 633$ nm have been shown to be successful [20]. The bond surfaces must also be free from organics, particulates, deposits from polishing and residues [27]. Both bonding surfaces must be thoroughly cleaned in a clean environment prior to bonding. Parts are produced to a flatness of $\lambda/10$ and an Ra roughness of 5 nm (Ra roughness is an arithmetic average deviation from the mean). The flatness and roughness of these parts are then measured before bonding is carried out. This leads to production of very thin bonds (<100 nm) which is important in creating suspensions for gravitational wave detectors as the volume of bond material has an effect on the mechanical loss of the overall suspension and thus on the thermal noise performance [28].

The time taken for a bond to form is dependent upon temperature and the pH of the solution, with bonding time increasing with decreasing temperature and with increasing hydroxide concentration [6]. Here the bonding procedure was carried out at room temperature (~ 293 K) and all of bonding solutions used had a pH of 12.

2.1. Bonding procedure

In previous experiments involving bonding sapphire using a KOH bonding solution, some relatively low values of strength were found (e.g. 1.5 MPa [25], 6.53 MPa [26]); however, the pH of the KOH solution used is not known [25] and no alternative bonding solutions were investigated. Here, KOH and three other solutions are considered for comparison.

The bonding solutions used were aqueous solutions of sodium aluminate (NaAlO_2), sodium hydroxide (NaOH), sodium silicate (Na_2SiO_3) and potassium hydroxide (KOH). Sodium aluminate and sodium hydroxide were chosen with the aim of closely matching the refractive index of the bond to that of the sapphire samples. Sodium silicate was chosen to allow comparison of the results obtained at Glasgow with prior studies of bond properties using this type of bonding solution to joint fused silica samples. Potassium hydroxide was chosen to allow comparison to results found by Dari *et al* [25] when bonding sapphire.

All solutions were prepared to produce a pH of 12. The pH of each solution was measured after the solutions were prepared using a Mettler Toledo SevenMulti bench top meter¹. The sodium aluminate solution was prepared with 0.04 g of sodium aluminate powder with 12.5 ml of de-ionized water. The sodium hydroxide solution was a 0.01 M solution in de-ionized water. The sodium silicate solution was a commercially available solution (14% NaOH and 27% SiO_2) diluted with de-ionized water at a volumetric ratio of 1:6, as used in previous studies [20]. The potassium hydroxide solution was prepared with a volumetric ratio of 1:190 KOH:H₂O with de-ionized water. Further to this, since KAGRA is intended to operate at cryogenic temperatures subsequently to room temperature operation, sodium silicate bond strengths were measured both at 77 K and at room temperature.

For the strength tests, 100 undoped sapphire cuboids (with dimensions 20 mm \times 10 mm \times 5 mm) were manufactured by Crystran². The bonding surface used was the 5 mm \times 10 mm surface and the normal to the bonding surface was perpendicular to both the *a*-axis and to the *c*-axis (as shown in figure 1, figure 2 shows a photograph of an example of a bonded pair

¹ www.keison.co.uk/mettlertoledo.shtml

² www.crystran.co.uk

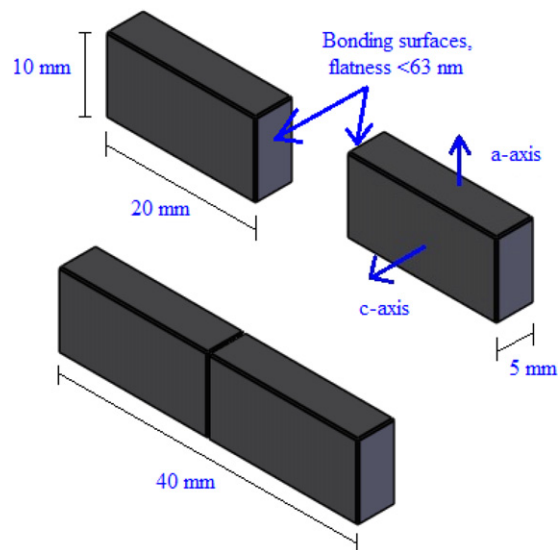

Figure 1. Diagram showing the geometry of the unbonded and bonded samples. The bonding surface is perpendicular to both the a -axis and the c -axis of the sapphire samples. There is a chamfer of approximately 0.16 mm on the bonding edges.

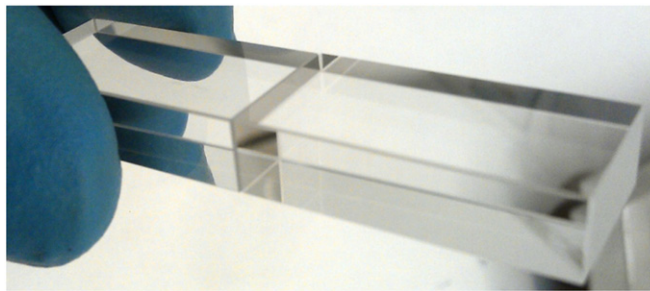

Figure 2. Photograph showing an example of a pair of bonded sapphire samples.

of sapphire samples for clarity). These bonding surfaces were polished to a nominal peak-to-valley flatness of $\lambda/10$ where $\lambda = 633 \text{ nm}$. The flatness of each surface was measured, before bonding, with a Zygo GPI XP/D interferometer at 633 nm.³ All samples were labelled with identification numbers.

In all cases the bond surfaces were cleaned with cerium oxide in de-ionized water, followed by cleaning with sodium bicarbonate, rinsing with de-ionized water and finally rinsing with methanol. This process removes residues, organics and particulates as well as small surface micro-peaks produced by polishing and produces a highly hydrophilic surface [29]. Finally, and immediately before bonding, the samples were inspected visually and wiped with a clean room cloth soaked in methanol. The bonding solution was passed through a medical filter with a $0.2 \mu\text{m}$ pore size and pipetted onto one of the bonding surfaces immediately after cleaning ($0.4 \mu\text{l}$ of solution per cm^2 of surface area). The second sample was then carefully aligned and placed on top of the first and the bonds were allowed to cure at room temperature for four weeks.

³ www.zygo.com

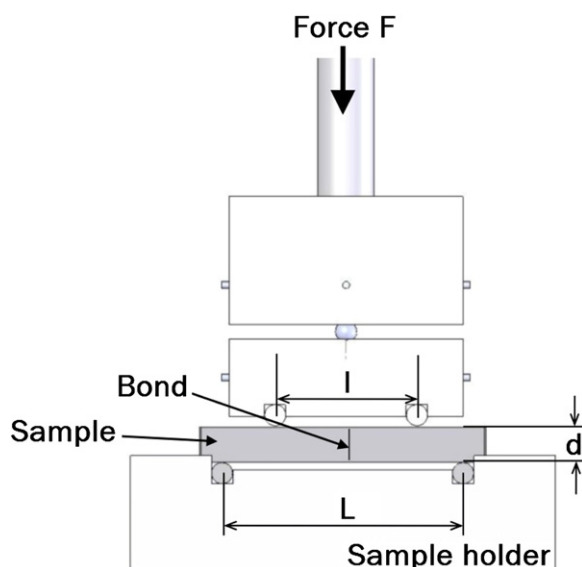

Figure 3. Schematic of four-point bending test. This allows an even force to be applied from above whilst the sample is supported from below such that a constant bending moment is applied between the top supports causing a compressive stress at the top and a tensile stress at the bottom. The force is steadily increased by moving the upper stage downwards at a rate of 2 mm min^{-1} until the sample breaks, and the total force required to do so is recorded [24].

Visually, bonds initially have a high optical reflectivity, and become optically transparent with time. When bonding with sodium silicate solution this process takes on the order of an hour, whilst with other solutions it takes a few minutes. Unlike hydroxide-catalysis bonding of fused silica, bond success with sodium aluminate and sodium hydroxide solutions appears to be binary—those which become transparent tend to do so across the entire bonding surface, with small gaps and visible bubbles in the bonding interface being rare and, if present, always centrally located. If the bonds stay visually reflective they are not strong enough to hold the weight of the samples, and generally the samples appear not to have bonded at all. This occurred with three sodium aluminate bonds and with one sodium hydroxide bond. The samples involved were cleaned, their surface flatnesses and roughnesses were re-measured and—since no changes in the surfaces were detected—they were re-bonded.

When bonding with sodium silicate solution, bubbles were observed to occasionally occur. Where incomplete bonds or bonds containing bubbles did form, this was recorded to assess whether this had any effect on the final strength of the bond.

3. Strength testing

The bond strength was tested using a four-point bending test, as shown in figure 3. The force, F , was applied through a loading arm until the sample broke. The supports below the sample were placed a distance $L = 34 \pm 0.5 \text{ mm}$ apart and the force was applied equally through two line contacts on top of the sample a distance $l = 20 \pm 0.5 \text{ mm}$ apart. This method allows the force to be evenly applied from above whilst the sample is supported from below. In the case of incomplete bonds, the more complete bond edge was always placed facing down.

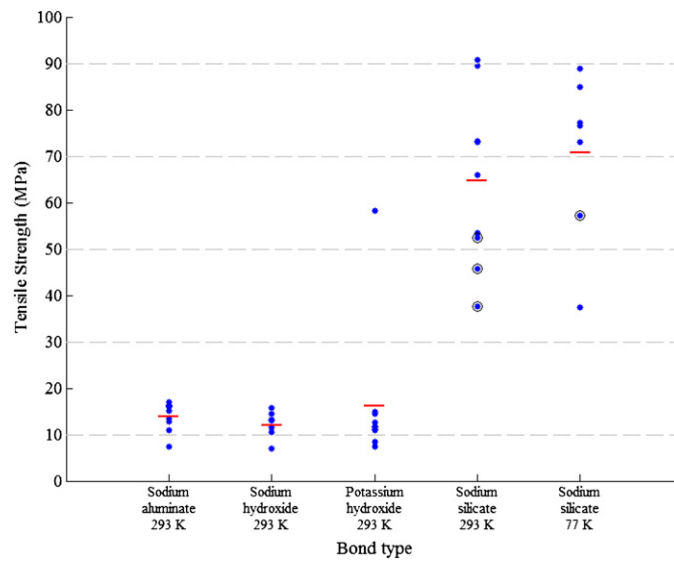

Figure 4. Strengths of bonds produced using various bonding solutions. The strengths are the blue points, the mean strength found for each set of samples is represented by the red bar. Circled points represent those results for which the bond covered approximately less than 90% of the bond area. It should be noted that although there is an apparently significant spread in the results even the weakest bonds measured were significantly stronger than would be required in a typical suspension [28].

The strength of the bond was then obtained from the maximum force recorded using equation (1) below [24]:

$$\sigma_{\max} = \frac{3(L-l)F}{2bd^2}, \quad (1)$$

where b is the sample thickness and d is the sample width (in this case 5.00 ± 0.005 mm and 10.00 ± 0.005 mm, respectively).

With 98 cuboids this allowed 49 bonded samples to be created; 10 bonded with sodium aluminate solution, 10 were bonded with sodium hydroxide solution, 10 were bonded with sodium silicate solution and 10 were bonded with potassium hydroxide solution.

4. Results

Figure 4 shows the complete set of the bond strength results that were obtained. Sodium silicate solution consistently produced stronger bonds than the other solutions. A further nine sample pairs were bonded with sodium silicate solution and broken at 77 K in liquid nitrogen. The strength of sodium silicate bonds was undiminished at these cryogenic temperatures.

In the case of those samples broken at cryogenic temperatures, the samples and breaking equipment were first placed in a bath that was filled with liquid nitrogen to cool the set-up to approximately 77 K (see figure 5). The bath was re-filled with liquid nitrogen between the breaking of each sample. This allowed comparison with strength results measured at room temperature. The cryogenic and room temperature experiments were not carried out on the same day, to remove any risk of unintentionally cooling the room temperature set-up.

Sodium aluminate, sodium hydroxide and potassium hydroxide solutions produced similar bonds; sodium aluminate bonds had a mean strength of 14 MPa with a minimum strength of

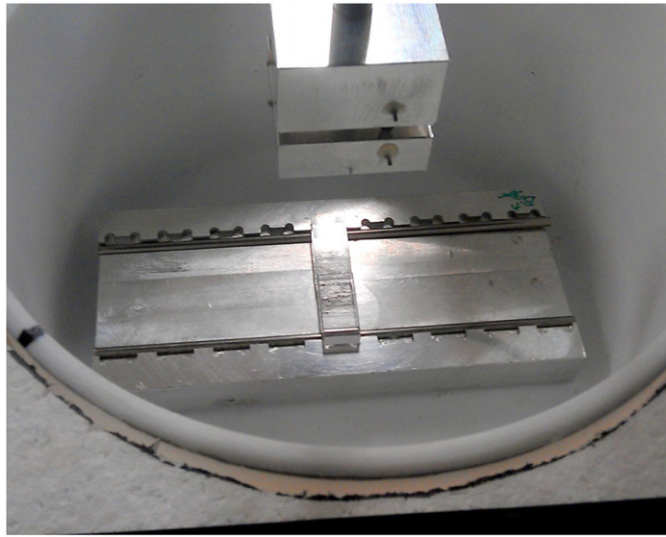

Figure 5. Photograph showing the liquid nitrogen bath in which the samples and breaking equipment were cooled for cryogenic strength tests. The bath was filled with liquid nitrogen and the samples were completely submerged. This reduced the sample temperatures to ~ 77 K.

7 MPa and a maximum strength of 17 MPa, sodium hydroxide bonds had a mean strength 12 MPa with a minimum strength of 7 MPa and a maximum strength of 16 MPa and potassium hydroxide bonds has a mean strength of 16 MPa with a minimum strength of 7 MPa and a maximum strength of 58 MPa. Bonds produced with sodium silicate solution were consistently stronger; bonds broken at room temperature had a mean strength of 65 MPa with a minimum strength of 38 MPa and a maximum strength of 91 MPa whilst bonds broken at 77 K had a mean strength of 70 MPa with a minimum strength of 38 MPa and a maximum strength of 89 MPa. It should be noted that although there is an apparently significant spread in the results even the weakest bonds measured would be significantly stronger than would be required in a typical suspension [28]. The spread of strength results produced with sodium silicate solution bonds was much greater than that produced with the other bonding solutions. This may be related to the greater likelihood of producing incomplete bonds when using the sodium silicate solution, especially when compared with the other solutions which, as mentioned before, appeared to bond with binary success; either creating complete, optically clear bonds or else no bond at all.

In almost every case the bonded samples broke across the bond, only in three cases, all with sodium silicate solution, was the bulk sapphire damaged in breaking (see figures 6 and 7). This may have been due to small flaws in the bulk sapphire or to micro-scratches in the (non-bonding) surfaces. The bonds that broke this way do not seem to have been particularly strong or particularly weak in comparison with similar bonds.

4.1. 'False breaks'

On two occasions 'false breaks' were recorded. In the case of the sodium silicate set tested at room temperature, one bond was too strong to be broken with the load cell. A strength of 91 MPa was recorded before it became impossible to increase the load further; this test was



Figure 6. Sample broken across the bond.



Figure 7. Broken sample with damage to the bulk sapphire.

repeated using a load cell with a higher rating and a strength of 75 MPa was then recorded. For later tests the greater load cell was consistently used.

In the case of the sodium silicate set tested at 77 K, one bond appeared to break (i.e. the machine detected a break and stopped). When it was removed from the liquid nitrogen bath it was clear that the bond was still intact (we postulate that some small particle was in the way and when that was damaged the abrupt change in stress led to the machine recording the false break). The strength recorded during this first attempt at breaking the bond was 42 MPa. The temperature of the sample was allowed to return to room temperature, before being re-submerged in the liquid nitrogen bath for a second breaking attempt. The second attempt was successful and the strength recorded was 99 MPa.

The data recorded from these two false breaks are not included in the plot or error bars shown in figure 4.

5. Discussion and summary

Bend strength tests were carried out on hydroxide-catalysis bonds formed between sapphire samples with bonds produced using four different bonding solutions: sodium aluminate, sodium hydroxide, potassium hydroxide and sodium silicate. It was found that the type of solution used had considerable influence on the strength of the bond produced and that sodium silicate solution produced the strongest bonds. The strengths recorded for sodium silicate bonds appeared undiminished when bonds were broken at cryogenic temperatures.

A very small number of bonds when broken resulted in damage to the bulk sapphire, however the level of damage does not seem to be related to the strength of the bond. All such bonds were produced with sodium silicate solution.

Sodium aluminate, sodium hydroxide and potassium hydroxide solutions produced similar bonds; sodium aluminate bonds had a mean strength of 14 MPa with a minimum strength of 7 MPa and a maximum strength of 17 MPa, sodium hydroxide bonds had a mean strength

12 MPa with a minimum strength of 7 MPa and a maximum strength of 16 MPa and potassium hydroxide bonds has a mean strength of 16 MPa with a minimum strength of 7 MPa and a maximum strength of 58 MPa. Bonds produced with sodium silicate solution were consistently stronger; bonds broken at room temperature had a mean strength of 65 MPa with a minimum strength of 38 MPa and a maximum strength of 91 MPa whilst bonds broken at 77 K had a mean strength of 70 MPa with a minimum strength of 38 MPa and a maximum strength of 89 MPa. However, all bonds were significantly stronger than would be required in a typical suspension [28]. The spread of strength results produced with sodium silicate solution bonds was much greater, as can be seen from figure 4. This could be due to a slightly reduced consistency in the quality of the bonds produced with this solution, with more bonds containing bubbles than seen in those bonds produced using the other solutions.

Although sodium silicate solution produced the strongest bonds, other solutions may still be suitable for bonding as all bonding solutions were used to produce bonds that would be strong enough for use in a typical suspension [28]. In previous studies concerning the bonding of similar pieces of fused silica, average breaking stresses of 18 MPa were recorded [19]. Studies that have used sodium silicate solution to bond pieces of silicon have found a mean strength of 36 MPa [23]

Acknowledgments

We would like to thank John Davidson from the University of Glasgow School of Engineering for his help with the strength measurements and Alastair Grant for general advice. The authors would like to thank the UK Science and Technology Facilities Council, the University of Glasgow, the Scottish Funding Council (grant number ST/L000946/1) and the Royal Society (grant number DH120021) for financial support. We also wish to thank our colleagues in the GEO 600 and LIGO Scientific Collaboration for their interest in this work. SR is a Royal Society-Wolfson Research Merit Award holder. AAV is the holder of a Royal Society Dorothy Hodgkin Fellowship. This work has been performed with the support of the European Commission under the Framework Program 7 (FP7) ‘People’ and project ELiTES (grant agreement 295153).

References

- [1] Gwo D-H, Wang S, Bower K A, Davidson D E, Ehrensberger P, Huff L, Romero E, Sullivan M T, Triebes K and Lipa J A 2003 The Gravity Probe-B star-tracking telescope *Adv. Space Res.* **32** 1401–5
- [2] Gwo D-H 2001 Ultra precision and reliable bonding method *US Patent* 6,284,085
- [3] Rowan S, Twyford S M, Hough J, Gwo D-H and Route R 1998 Mechanical losses associated with the technique of hydroxide-catalysis bonding of fused silica *Phys. Lett. A* **246** 471–8
- [4] Amico P, Bosi L, Carbone L, Gammaitoni L, Marchesoni F, Punturo M, Travasso F and Vocca H 2002 Monolithic fused silica suspension for the Virgo gravitational wave detector *Rev. Sci. Instrum.* **73** 3318–23
- [5] Cumming A V *et al* 2012 Design and development of the Advanced LIGO monolithic fused silica suspension *Class. Quantum Grav.* **29** 035003
- [6] Reid S, Cagnoli G, Crooks D R M, Hough J, Murray P, Rowan S, Fejer M M, Route R and Zappe S 2006 Mechanical dissipation in silicon flexures *Phys. Lett. A* **351** 205–11
- [7] Abbott B P *et al* 2009 LIGO: the laser interferometer gravitational-wave observatory *Rep. Prog. Phys.* **72** 076901
- [8] Accadia T *et al* 2010 Commissioning status of the Virgo interferometer *Class. Quantum Grav.* **27** 084002
- [9] Grote H *et al* 2010 The GEO 600 status *Class. Quantum Grav.* **27** 084003

- [10] Takahashi R *et al* 2008 Operational status of TAMA300 with the seismic attenuation system (SAS) *Class. Quantum Grav.* **25** 114036
- [11] Willke B *et al* 2002 The GEO 600 gravitational wave detector *Class. Quantum Grav.* **19** 1377
- [12] Harry G M *et al* 2010 Advanced LIGO: the next generation of gravitational wave detectors *Class. Quantum Grav.* **27** 084006
- [13] Accadia T *et al* 2011 Status of the Virgo project *Class. Quantum Grav.* **28** 114002
- [14] Somiya K 2012 Detector configuration of KAGRA—the Japanese cryogenic gravitational-wave detector *Class. Quantum Grav.* **29** 124007
- [15] Punturo M *et al* 2010 The Einstein telescope: a third-generation gravitational wave observatory *Class. Quantum Grav.* **27** 194002
- [16] Braginsky V B 1985 *Systems with Small Dissipation* 2nd edn (Chicago, IL: University of Chicago Press)
- [17] Uchiyama T, Tatsumi D, Tomaru T, Tobar M E, Kuroda K, Suzuki T, Sato N, Yamamoto A, Haruyama T and Shintomi T 1998 Cryogenic cooling of a sapphire mirror-suspension for interferometric gravitational wave detectors *Phys. Lett. A* **242** 211–4
- [18] Nawrodt R, Rowan S, Hough J, Punturo M, Ricci F and Vinet J-Y 2011 Challenges in thermal noise for 3rd generation of gravitational wave detectors *Gen. Rel. Grav.* **43** 593–622
- [19] Haughian K A 2012 Aspects of materials research for advanced and future generations of gravitational wave detectors *PhD Thesis* University of Glasgow
- [20] Elliffe E J, Bogenstahl J, Deshpande A, Hough J, Killow C, Reid S, Robertson D, Rowan S, Ward H and Cagnoli G 2005 Hydroxide-catalysis bonding for stable optical systems for space *Class. Quantum Grav.* **22** S257
- [21] Van Veggel A A, Van Den Ende D, Bogenstahl J, Rowan S, Cunningham W, Gubbels G H M and Nijmeijer H 2008 Hydroxide catalysis bonding of silicon carbide *J. Eur. Ceram. Soc.* **28** 303–10
- [22] Killow C J, Fitzsimons E D, Hough J, Perreux-Lloyd M, Robertson D I, Rowan S and Ward H 2013 Construction of rugged, ultrastable optical assemblies with optical component alignment at the few microradian level *Appl. Opt.* **52** 177–81
- [23] Beveridge N L *et al* 2011 Low-temperature strength tests and sem imaging of hydroxide catalysis bonds in silicon *Class. Quantum Grav.* **28** 085014
- [24] Beveridge N L, van Veggel A A, Cunningham L, Hough J, Martin I W, Nawrodt R, Reid S and Rowan S 2013 Dependence of cryogenic strength of hydroxide catalysis bonded silicon on type of surface oxide *Class. Quantum Grav.* **30** 025003
- [25] Dari A, Travasso F, Vocca H and Gammaitoni L 2010 Breaking strength tests on silicon and sapphire bondings for gravitational wave detectors *Class. Quantum Grav.* **27** 045010
- [26] Suzuki T *et al* 2006 Application of sapphire bonding for suspension of cryogenic mirrors *J. Phys.: Conf. Ser.* **32** 309
- [27] Green K, Burke J and Oreb B 2011 Chemical bonding for precision optical assemblies *Opt. Eng., Bellingham* **50** 023401
- [28] Cunningham L *et al* 2010 Re-evaluation of the mechanical loss factor of hydroxide-catalysis bonds and its significance for the next generation of gravitational wave detectors *Phys. Lett. A* **374** 3993–8
- [29] Preston A, Balaban B and Mueller G 2008 Hydroxide-bonding strength measurements for space-based optical missions *Int. J. Appl. Ceram. Technol.* **5** 365–72