



Geometry & Topology

Volume 27 (2023)

Filtering the Heegaard Floer contact invariant

ÇAĞATAY KUTLUHAN

GORDANA MATIĆ

JEREMY VAN HORN-MORRIS

ANDY WAND



Filtering the Heegaard Floer contact invariant

ÇAĞATAY KUTLUHAN

GORDANA MATIĆ

JEREMY VAN HORN-MORRIS

ANDY WAND

We define an invariant of contact structures in dimension three from Heegaard Floer homology. This invariant takes values in the set $\mathbb{Z}_{\geq 0} \cup \{\infty\}$. It is zero for overtwisted contact structures, ∞ for Stein-fillable contact structures, nondecreasing under Legendrian surgery, and computable from any supporting open book decomposition. As an application, we give an easily computable obstruction to Stein-fillability on closed contact 3-manifolds with nonvanishing Ozsváth–Szabó contact class.

57R17; 57R58

1. Introduction	2181
2. Definitions	2186
3. Dependence on choices	2193
4. Properties of \mathfrak{o}	2210
5. Obstructing Stein-fillability	2219
References	2233

1 Introduction

Let M be a closed orientable 3-manifold and ξ be a contact structure on M . The goal of this article is to define an invariant of (M, ξ) as a refinement of the contact invariant in Heegaard Floer homology, the *Ozsváth–Szabó contact class* $\hat{c}(\xi)$ [50], and to study some of its properties. To define our invariant, we start from an open book decomposition of M supporting ξ and a collection of pairwise disjoint properly embedded arcs on a page of the open book decomposition. From this data we build a

filtered chain complex out of the corresponding Heegaard Floer chain complex, whose filtration captures in an algebraic sense the topological complexity of curves counted by the differential. We then consider how far the Ozsváth–Szabó contact class survives in the associated spectral sequence. The result is an invariant of the contact manifold, denoted by $\mathfrak{o}(M, \xi)$, and read the *spectral order*, or simply *order*, of (M, ξ) , taking values in $\mathbb{Z}_{\geq 0} \cup \{\infty\}$.

Theorem 1.1 *The contact invariant \mathfrak{o} satisfies the following properties:*

- $\mathfrak{o}(M, \xi) = 0$ if (M, ξ) is overtwisted.
- $\mathfrak{o}(M, \xi) = \infty$ if (M, ξ) is Stein-fillable.
- $\mathfrak{o}(M, \xi)$ can be detected on an arbitrary supporting open book decomposition of (M, ξ) .

The second bullet point property in Theorem 1.1 follows from the fact that the contact invariant \mathfrak{o} behaves well under Legendrian surgery, giving a map of partially ordered sets from contact manifolds ordered by Stein cobordisms to the set $\mathbb{Z}_{\geq 0} \cup \{\infty\}$ with the usual ordering:

Theorem 1.2 *The contact invariant \mathfrak{o} is nondecreasing under Legendrian surgery and in particular gives an obstruction to the existence of Stein cobordisms between contact 3-manifolds. Specifically, if (M_-, ξ_-) and (M_+, ξ_+) are respectively the concave and convex ends of a Stein cobordism, then $\mathfrak{o}(M_-, \xi_-) \leq \mathfrak{o}(M_+, \xi_+)$.*

Aside from the properties listed in Theorem 1.1, the contact invariant \mathfrak{o} behaves well under connected sums. To be more explicit:

Theorem 1.3 *Let (M_1, ξ_1) and (M_2, ξ_2) be closed contact 3-manifolds. Then their connected sum satisfies $\mathfrak{o}(M_1 \# M_2, \xi_1 \# \xi_2) = \min\{\mathfrak{o}(M_1, \xi_1), \mathfrak{o}(M_2, \xi_2)\}$.*

The above theorem fits into a broader pattern of similar contact connected sum results. Loosely, various measures of rigidity of $(M_1 \# M_2, \xi_1 \# \xi_2)$ — for example, Stein-fillability, having a nonvanishing Ozsváth–Szabó contact class, or tightness — is the weaker of that property for (M_1, ξ_1) or (M_2, ξ_2) (see Eliashberg [11], Cieliebak and Eliashberg [7], Ozsváth and Szabó [50] and Colin [8]). In addition, Theorem 1.3 leads to existence of a family of monoids $\mathfrak{o}^k(S)$ in the mapping class group $\text{Mod}(S, \partial S)$: $\phi \in \text{Mod}(S, \partial S)$ belongs to $\mathfrak{o}^k(S)$ if and only if $\mathfrak{o} \geq k$ for the contact 3-manifold specified by the open book decomposition (S, ϕ) .

Our contact invariant is inspired by an analog of Latschev and Wendl's algebraic torsion introduced by Hutchings in the context of embedded contact homology (ECH) in [33, Appendix]. To a closed oriented 3-manifold M , a nondegenerate contact 1-form λ on M , and a generic almost complex structure J on $\mathbb{R} \times M$ as needed to define the ECH chain complex, Hutchings associates a number $f(M, \lambda, J)$ in $\mathbb{Z}_{\geq 0} \cup \{\infty\}$. The latter is shown to vanish for overtwisted contact structures for all choices of λ and J , and can be used to obstruct exact symplectic cobordisms. Our initial definitions follow the ideas of Hutchings' construction, ported to the setting of Heegaard Floer homology (see our work [32] for more on this). We choose to work with Heegaard Floer homology because of its computational advantages.

As an application, it follows from the second bullet point above that, even for closed contact 3-manifolds with nonvanishing Ozsváth–Szabó contact class, one can obstruct Stein-fillability by finding a finite upper bound on its spectral order, which is easier than computing the spectral order itself.

Theorem 1.4 *There is an infinite family of contact 3-manifolds $\{(Y_p, \xi_p)\}_{p \in \mathbb{Z}_{>0}}$ each with $\hat{c}(\xi_p) \neq 0$ but with $\mathfrak{o}(Y_p, \xi_p) = 0$ (see Figure 19, left, for a description of this family via open book decompositions). In particular, these contact 3-manifolds are not Stein-fillable.*

Remark During the course of this project we learned that John Baldwin and David Shea Vela-Vick have independently been working on a filtration in Heegaard Floer homology similar in spirit to the J_+ -filtration defined in Section 2.2. This led to an interesting application in knot Floer homology [4].

Future considerations

In upcoming work in progress [31], we present an infinite family of contact structures with vanishing Ozsváth–Szabó contact class but with nonzero spectral order. Furthermore, we compute upper bounds on the spectral order of these contact structures and these upper bounds span the range of all positive integers. The next step will be to show that there is an increasing sequence of positive integers that provides lower bounds on the spectral order of our family of contact structures. These computations would resolve the following conjecture:

Conjecture 1.5 *An infinite sequence of distinct positive integers is realized by the spectral order of an infinite family of contact structures with vanishing Ozsváth–Szabó contact class.*

In addition, such a family of examples would provide a nested sequence of monoids

$$\dots \subsetneq \mathfrak{o}^{k_{n+1}}(S) \subsetneq \mathfrak{o}^{k_n}(S) \subsetneq \dots,$$

where $\mathfrak{o}^{k_n}(S)$ is the set of orientation-preserving homeomorphisms ϕ in the mapping class group $\text{Mod}(S, \partial S)$ such that the open book decomposition (S, ϕ) supports a contact structure with $\mathfrak{o} \geq k$, and S may have arbitrary genus. Note that this family of monoids would be contained in the monoid $\text{Tight}(S, \partial S)$ and would contain the monoid $\text{Stein}(S, \partial S)$ (see Etnyre and Van Horn-Morris [13], as well as Baldwin [3] and Baker, Etnyre and Van Horn-Morris [1]), and it would provide an answer to [13, Question 6.8].

A more conceptual question concerns the potential of a converse to the first bullet point of Theorem 1.1:

Question 1.6 *Suppose that (M, ξ) has vanishing Ozsváth–Szabó contact class. Does $\mathfrak{o}(M, \xi) = 0$ imply that ξ is overtwisted?*

An affirmative answer to Question 1.6 would imply that Heegaard Floer package detects tight contact structures. In this regard, spectral order gives a potential interpretation of *consistency* of an open book decomposition (see Wand [55]), a combinatorial condition equivalent to tightness of the supported contact structure, in the context of pseudoholomorphic curves. Furthermore, along with the nondecreasing behavior of spectral order under Legendrian surgery, an affirmative answer to Question 1.6 would provide an alternative and more conceptual proof of the following theorem, which has recently been proved by the last author in [56]:

Theorem 1.7 *Let ξ be a tight contact structure on M , and $K \subset M$ be a null-homologous Legendrian knot. Then contact (-1) -surgery on K produces a 3-manifold with a tight contact structure.*

Another question of interest is related to generalizing our invariant to compact contact 3-manifolds with convex boundary. In this regard, our construction of a filtered chain complex out of the Heegaard Floer chain complex readily generalizes to the case of partial open book decompositions introduced by Honda, Kazez and Matić [22]. This allows us to extend the definition of spectral order (Definition 2.2) to compact contact 3-manifolds with convex boundary. This was independently observed by Juhász and Kang [26], who used it to find an upper bound on the spectral order for a closed contact 3-manifold that contains a Giroux torsion domain. More generally, Juhász and Kang showed that the spectral order of a codimension zero contact submanifold with convex

boundary gives an upper bound on the spectral order of the ambient manifold. Among other things, we will compare o to Wendl's *planar torsion* [58]. As is stated by Latschev and Wendl [33, Theorem 6], planar torsion provides an upper bound to Latschev and Wendl's algebraic torsion. Moreover, planar torsion detects overtwistedness. One could expect a similar relationship between spectral order and Wendl's planar torsion. These are the content of another work in progress by the authors [30].

Question 1.8 *Suppose that the closed contact 3-manifold (M, ξ) has planar k -torsion. Does this imply $o(M, \xi) \leq k$?*

Organization

In Section 2, we provide the definitions required throughout the article, leading to the definition of spectral order. These include a preliminary version of the latter, denoted by o , which a priori depends on the choices made to define it.

Section 3 investigates the dependence of o on various choices made in its definition. Among these are a choice of the monodromy of an open book decomposition in its isotopy class and a choice of a collection of pairwise disjoint properly embedded arcs on a page of an open book decomposition.

In Section 4, we exhibit several properties of spectral order, and in doing so prove Theorems 1.1, 1.2 and 1.3.

In Section 5, we present an infinite family of contact structures with nonvanishing Ozsváth–Szabó contact class but with zero spectral order. This implies, by Theorem 1.1, that these contact structures are not Stein-fillable. We also compare our method to other known obstructions to fillability of closed contact 3-manifolds.

Acknowledgements

The seeds of this project were sown at the *Interactions between contact symplectic topology and gauge theory in dimensions 3 and 4* workshop at Banff International Research Station (BIRS) in 2011. Kutluhan, Matić and Van Horn-Morris would like to thank BIRS and the organizers of that workshop for creating a wonderful atmosphere for collaboration. We also thank John Baldwin for some helpful conversations, Michael Hutchings for generously sharing his thoughts on the ECH analog of algebraic torsion, and Robert Lipshitz for several very helpful correspondences. A significant portion of this work was completed while Kutluhan was a member and Matić, Van Horn-Morris and Wand were visitors at the Institute for Advanced Study (IAS) in Princeton. We

thank IAS faculty, particularly Helmut Hofer, and staff for their hospitality. We are also very grateful to the American Institute of Mathematics (AIM). This project benefited greatly from the AIM SQuARE program. In addition, Matić and Van Horn-Morris thank the Max Planck Institute for Mathematics (MPIM) in Bonn for their support and hospitality. Part of this work was completed while they were visiting MPIM. Finally, we thank the referees for several helpful comments and corrections.

Kutluhan was supported in part by NSF grant DMS-1360293 and Simons Foundation grant 519352. Matić was supported in part by Simons Foundation grant 246461 and NSF grant DMS-1664567. Van Horn-Morris was supported in part by Simons Foundation grants 279342 and 639259 and NSF grant DMS-1612412. Wand was supported in part by ERC grant GEODYCON and EPSRC EP/P004598/1.

2 Definitions

2.1 Background

To set the stage, let M be a closed, connected and oriented 3–manifold endowed with a cooriented contact structure ξ . It is understood that the orientation on M is induced by ξ . A celebrated theorem of Giroux states that there is a one-to-one correspondence between contact structures up to isotopy and open book decompositions up to positive stabilization [17]. An abstract open book decomposition of M is a pair (S, ϕ) , where S is a compact oriented surface of genus g with B boundary components, called the *page*, and ϕ is an orientation-preserving diffeomorphism of S which restricts to the identity in a neighborhood of the boundary, called the *monodromy*. The manifold M is homeomorphic to $S \times [0, 1]/\sim$, where $(p, 1) \sim (\phi(p), 0)$ for any $p \in S$ and $(p, t) \sim (p, t')$ for any $p \in \partial S$ and $t, t' \in [0, 1]$. The open book decomposition is said to support the contact structure ξ if there exists a 1–form λ such that $\xi = \ker(\lambda)$, $\lambda|_{\partial S} > 0$ and $d\lambda|_S > 0$.

Now fix an abstract open book decomposition (S, ϕ) of M supporting ξ and a collection of pairwise disjoint properly embedded arcs $\mathbf{a} = \{a_1, \dots, a_N\}$ on S that contains a basis, that is, a subcollection of arcs cutting S into a polygon. This arc collection together with the monodromy ϕ defines a Heegaard diagram $(\Sigma, \{\beta_1, \dots, \beta_N\}, \{\alpha_1, \dots, \alpha_N\})$ for $-M$ as in [23, Section 3.1]. To be more explicit, let $\mathbf{b} = \{b_1, \dots, b_N\}$ be a collection of arcs on S where b_i is isotopic to a_i via a small isotopy satisfying the following conditions:

- The endpoints of b_i are obtained from the endpoints of a_i by pushing along ∂S in the direction of the boundary orientation.

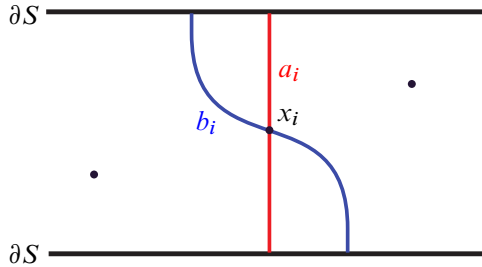

Figure 1: The arcs a_i and b_i on the surface S .

- a_i intersects b_i transversally at one point, x_i , in the interior of S .
- Having fixed an orientation of a_i , there is an induced orientation on b_i , and the sign of the oriented intersection $a_i \cap b_i$ is positive (see Figure 1).

Then $\Sigma = S \times \{\frac{1}{2}\} \cup_{\partial S} -S \times \{0\}$, $\alpha_i = a_i \times \{\frac{1}{2}\} \cup a_i \times \{0\}$ and $\beta_i = b_i \times \{\frac{1}{2}\} \cup \phi(b_i) \times \{0\}$. Note that the Heegaard diagram $(-\Sigma, \{\alpha_1, \dots, \alpha_N\}, \{\beta_1, \dots, \beta_N\})$ also describes the manifold $-M$, and we may sometimes prefer to use this diagram in figures.

With the preceding understood, we recall the definition of the Heegaard Floer chain complex $(\widehat{CF}(\Sigma, \beta, \alpha), \widehat{\partial}_{HF})$. In doing so, we adopt Lipshitz’s cylindrical reformulation of Heegaard Floer homology [35]. The definition also requires the choice of basepoints $z \subset \Sigma \setminus \bigcup_{i \in \{1, \dots, N\}} (\alpha_i \cup \beta_i)$. In the present context, this is done according to the convention in [23, Section 3.1]. To be more explicit, place a single basepoint in every connected component of $S \setminus \bigcup_{i \in \{1, \dots, N\}} a_i$ outside the small strips between a_i and b_i (see Figure 1). Following Lipshitz, the chain group $\widehat{CF}(\Sigma, \beta, \alpha)$ is freely generated over $\mathbb{F} := \mathbb{Z}/2\mathbb{Z}$ by I -chord collections $\vec{x} := x \times [0, 1]$ specified by unordered N -tuples of points in Σ of the form $x = \{x_1, \dots, x_N\}$, where $x_i \in \alpha_i \cap \beta_{\sigma(i)}$ for some element σ of the symmetric group S_N . Given a generic almost complex structure J_{HF} on $\Sigma \times [0, 1] \times \mathbb{R}$ satisfying conditions (J1)–(J5) in [35, Section 1, page 959], the differential $\widehat{\partial}_{HF}$ on $\widehat{CF}(\Sigma, \beta, \alpha)$ is defined to be the endomorphism of $\widehat{CF}(\Sigma, \beta, \alpha)$ sending a generator \vec{x} to

$$\sum_{\vec{y}} \sum_{\substack{A \in \widehat{\pi}_2(\vec{x}, \vec{y}) \\ \text{ind}(A)=1}} n(\vec{x}, \vec{y}; A) \vec{y}.$$

Here $\widehat{\pi}_2(\vec{x}, \vec{y})$ denotes the set of relative homology classes of continuous maps from a Riemann surface with boundary and boundary punctures into $\Sigma \times [0, 1] \times \mathbb{R}$ such that it maps the boundary of the surface into $\alpha \times \{0\} \times \mathbb{R} \cup \beta \times \{1\} \times \mathbb{R}$, it converges to \vec{x} and \vec{y} at its punctures, and it has trivial homological intersection with $\{z\} \times [0, 1] \times \mathbb{R}$.

Meanwhile, $\text{ind}(A)$ denotes the index of a class $A \in \widehat{\pi}_2(\vec{x}, \vec{y})$ (see [35, Definition 4.4]), and $n(\vec{x}, \vec{y}; A)$ is a signed count, modulo \mathbb{R} -translation, of J_{HF} -holomorphic curves in $\Sigma \times [0, 1] \times \mathbb{R}$ satisfying conditions (M0)–(M6) in [35, Section 1, page 960] and representing the class A . The latter is guaranteed to be finite if we choose the monodromy ϕ appropriately in its isotopy class so as to make the multipointed Heegaard diagram $(\Sigma, \beta, \alpha, z)$ *admissible*. A multipointed Heegaard diagram is admissible if every nontrivial periodic domain has both positive and negative coefficients (see [35, Definition 5.1]).

Remark Even though Lipshitz carried out his construction of a cylindrical reformulation of Heegaard Floer homology in the case $N = 2g + B - 1$ (in other words, the case with one basepoint), the details of his construction and especially the results in [35, Sections 4 and 10] carry over to the multipointed case but for cosmetic changes.

2.2 The J_+ filtration

Next we build a filtered chain complex out of $(\widehat{CF}(\Sigma, \beta, \alpha), \widehat{\partial}_{HF})$. To do this, we adopt Hutchings’ recipe in [24, Section 6]. Given a pair of generators \vec{x} and \vec{y} , define a function J_+ on $\widehat{\pi}_2(\vec{x}, \vec{y})$ by¹

$$(2-1) \quad J_+(A) := \mu(\mathcal{D}(A)) - 2e(\mathcal{D}(A)) + |\mathbf{x}| - |\mathbf{y}|,$$

where $|\cdot|$ denotes the number of disjoint cycles in the element of the symmetric group S_N associated to a given generator following the convention described above in Section 2.1 (eg the generator x_ξ corresponding to the distinguished set of points $\{x_1, \dots, x_N\}$ indicated in Figure 1 has $|\vec{x}_\xi| = N$), $\mathcal{D}(A)$ is the *domain* in the pointed Heegaard diagram $(\Sigma, \beta, \alpha, z)$ representing a class $A \in \widehat{\pi}_2(\vec{x}, \vec{y})$, $\mu(\mathcal{D}(A))$ is the *Maslov index* of $\mathcal{D}(A)$ as in the traditional setting of [48], and $e(\mathcal{D}(A))$ is the *Euler measure* of $\mathcal{D}(A)$ (see [35, Section 4.1, page 973] for the definition). Since the Maslov index and Euler measure are additive under concatenation of domains, so is J_+ . More precisely, for any $A \in \widehat{\pi}_2(\vec{x}, \vec{y})$ and $A' \in \widehat{\pi}_2(\vec{y}, \vec{z})$, we have

$$J_+(A + A') = J_+(A) + J_+(A').$$

Now suppose that $A \in \widehat{\pi}_2(\vec{x}, \vec{y})$ is represented by a J_{HF} -holomorphic curve C_L in $\Sigma \times [0, 1] \times \mathbb{R}$ satisfying conditions (M0)–(M6) in [35, Section 1]. Then, by [35, Proposition 4.2 (see also Proposition 4.2’ in the correction)],

$$(2-2) \quad \chi(C_L) = N - n_x(\mathcal{D}(A)) - n_y(\mathcal{D}(A)) + e(\mathcal{D}(A)).$$

¹The interested reader may refer to [32] to see how the authors originally came up with this formula.

Here, $n_p(\mathcal{D}(A))$ denotes the *point measure*, namely, the average of the coefficients of $\mathcal{D}(A)$ for the four regions with corners at $p \in \alpha_i \cap \beta_j$. Meanwhile, Lipshitz’s formula for the Maslov index of domains [35, Corollary 4.10 (see also Proposition 4.8’ in the correction)] asserts that

$$(2-3) \quad \mu(\mathcal{D}(A)) = n_x(\mathcal{D}(A)) + n_y(\mathcal{D}(A)) + e(\mathcal{D}(A)).$$

Combining (2-2) and (2-3), we obtain

$$\mu(\mathcal{D}(A)) - 2e(\mathcal{D}(A)) = -\chi(C_L) + N,$$

and hence (2-1) can be rewritten as

$$(2-4) \quad J_+(A) = -\chi(C_L) + N + |x| - |y|.$$

With the preceding understood, consider the smooth compact oriented surface C obtained from the compactification of C_L by attaching 2–dimensional 1–handles along pairs of points in $\alpha_i \times \{0\} \times \mathbb{R} \cap C_L$ and $\beta_i \times \{1\} \times \mathbb{R} \cap C_L$ for each $i = 1, \dots, N$, and then smoothing. Then $\chi(C) = \chi(C_L) - N$, and $|x|$ (resp. $|y|$) is equal to the number of boundary components of C arising from the I –chord \vec{x} (resp. \vec{y}). Hence, we can further rewrite (2-4) as

$$(2-5) \quad J_+(A) = \sum_{C_j \subset C} (2g_j - 2 + 2|x_j|),$$

where each C_j denotes a connected component of C , g_j denotes the genus of C_j , and each $x_j \subset x$ denotes the maximal subcollection of points in x such that $x_j \times [0, 1]$ lies on the boundary of the component C_j . Note that each connected component of C has nonempty intersections with the I –chord collections specified by x and y since each connected component of C_L has nonempty negative and positive ends. Therefore, it follows from (2-5) that $2 \mid J_+(A)$ and $J_+(A) \geq 0$.

Remark If there exists an embedded J_{HF} –holomorphic curve C_L representing the class A , then the Maslov index of $\mathcal{D}(A)$ agrees with the Fredholm index of C_L . For Maslov index-1 domains, we prefer to use the equivalent formula

$$(2-6) \quad J_+(A) = 2[n_x(\mathcal{D}(A)) + n_y(\mathcal{D}(A))] - 1 + |x| - |y|.$$

2.3 The filtered chain complex

Following Hutchings, we decompose the Heegaard Floer differential as

$$\widehat{\partial}_{HF} = \partial_0 + \partial_1 + \dots + \partial_l + \dots,$$

where ∂_l counts J_{HF} -holomorphic curves with $J_+ = 2l$ and having empty intersection with $\{z\} \times [0, 1] \times \mathbb{R}$. Since J_+ is additive under gluing of J -holomorphic curves, the above decomposition induces a spectral sequence with pages

$$E^k(S, \phi, \mathbf{a}; J_{HF}) = H_*(E^{k-1}(S, \phi, \mathbf{a}; J_{HF}), d_{k-1}).$$

To be more explicit, consider the \mathbb{Z} -graded module

$$\widehat{\mathcal{CF}}(S, \phi, \mathbf{a}) := \widehat{\mathcal{CF}}(\Sigma, \boldsymbol{\beta}, \boldsymbol{\alpha}) \otimes_{\mathbb{F}} \mathbb{F}[t, t^{-1}]$$

endowed with the endomorphism $\widehat{\partial}$ defined by

$$\widehat{\partial} \left(\sum_{i \in \mathbb{Z}} c_i t^i \right) := \sum_{i \in \mathbb{Z}} \left(\sum_{l \in \mathbb{Z}} (\partial_l c_i) t^{i-l} \right).$$

Here $c_i \neq 0$ for only finitely many $i \in \mathbb{Z}$. Note that the additivity property of J_+ implies that

$$\sum_{i+j=l} \partial_i \circ \partial_j = 0$$

for any $l \geq 0$; hence, $\widehat{\partial} \circ \widehat{\partial} = 0$, making $(\widehat{\mathcal{CF}}(S, \phi, \mathbf{a}), \widehat{\partial})$ into a filtered chain complex, where the p^{th} filtration level

$$\mathcal{F}^p(S, \phi, \mathbf{a}) = \left\{ \sum_{i \leq p} c_i t^i \mid c_i \in \widehat{\mathcal{CF}}(\Sigma, \boldsymbol{\beta}, \boldsymbol{\alpha}) \right\}.$$

Then $(E^k(S, \phi, \mathbf{a}; J_{HF}), d_k)$ is the spectral sequence associated to this filtered chain complex, where d_k is the restriction of $\widehat{\partial}$ to $E^k(S, \phi, \mathbf{a}; J_{HF})$. To be more explicit, let A_p^k denote the subcomplex defined by

$$A_p^k = \{c \in \mathcal{F}^p(S, \phi, \mathbf{a}) \mid \widehat{\partial}c \in \mathcal{F}^{p-k}(S, \phi, \mathbf{a})\},$$

ie

$$A_p^k = \left\{ \sum_{i \leq p} c_i t^i \mid c_i \in \widehat{\mathcal{CF}}(\Sigma, \boldsymbol{\beta}, \boldsymbol{\alpha}) \text{ with } \sum_{i=0}^j \partial_i c_{p+i-j} = 0 \text{ for } 0 \leq j < k \right\}.$$

Then

$$E_p^k(S, \phi, \mathbf{a}; J_{HF}) = \frac{A_p^k}{\widehat{\partial}A_{p+k-1}^{k-1} + A_{p-1}^{k-1}}.$$

A straightforward calculation shows that $E_0^k(S, \phi, \mathbf{a}; J_{HF})$ is isomorphic to

$$(2-7) \quad \frac{\mathcal{Z}^k(S, \phi, \mathbf{a}; J_{HF})}{\mathcal{B}^k(S, \phi, \mathbf{a}; J_{HF})},$$

where

$$\begin{aligned} Z^k(S, \phi, \mathbf{a}; J_{HF}) &:= \left\{ c_0 \in \widehat{CF}(\Sigma, \boldsymbol{\beta}, \boldsymbol{\alpha}) \mid \exists c_i \in \widehat{CF}(\Sigma, \boldsymbol{\beta}, \boldsymbol{\alpha}) \text{ for } 1-k \leq i \leq -1 \text{ with } \partial_0 c_0 = 0 \right. \\ &\quad \left. \text{and } \partial_j c_0 = \sum_{i=0}^{j-1} \partial_i c_{i-j} \text{ for } 0 < j < k \right\} \end{aligned}$$

and

$$\mathcal{B}^k(S, \phi, \mathbf{a}; J_{HF}) := \left\{ \sum_{i=0}^{k-1} \partial_i b_i \mid b_i \in \widehat{CF}(\Sigma, \boldsymbol{\beta}, \boldsymbol{\alpha}) \text{ and } \sum_{i=0}^{k-1-j} \partial_i b_{i+j} = 0 \text{ for } 0 < j < k \right\}.$$

(Note that, for an element $\sum_{i \leq 0} c_i t^i \in A_0^k$, the chains c_i for $1-k \leq i \leq -1$ are uniquely determined by c_0 up to chains a_i for $1-k \leq i \leq -1$ belonging to some $\sum_{i \leq -1} a_i t^i \in A_{-1}^{k-1}$, and that Z^k is isomorphic to A_0^k/A_{-1}^{k-1} .) Since $\mathcal{F}^p(S, \phi, \mathbf{a}) \cong \mathcal{F}^{p-1}(S, \phi, \mathbf{a})$ canonically as chain complexes, $E_p^k(S, \phi, \mathbf{a}; J_{HF})$ is canonically isomorphic to the quotient (2-7) for every p .

By [23, Theorem 3.1], the distinguished generator \vec{x}_ξ represents the Ozsváth–Szabó contact class $\hat{c}(\xi) \in \widehat{HF}(-M)$, and it satisfies $\partial_i \vec{x}_\xi = 0$ for all $i \geq 0$. This is because there is no Fredholm index-1 J_{HF} -holomorphic curve in $\Sigma \times [0, 1] \times \mathbb{R}$ satisfying conditions (M0)–(M6) in [35, Section 1] with \vec{x}_ξ at its negative punctures and having empty intersection with $\{z\} \times [0, 1] \times \mathbb{R}$. Hence, \vec{x}_ξ represents a cycle in $E^k(S, \phi, \mathbf{a}; J_{HF})$ for all $k \geq 1$.

Definition 2.1 Define $o(S, \phi, \mathbf{a}; J_{HF})$ to be the smallest nonnegative integer k such that the generator \vec{x}_ξ represents the trivial class in $E^{k+1}(S, \phi, \mathbf{a}; J_{HF})$.

Ideally, one would like to show that $o(S, \phi, \mathbf{a}; J_{HF})$ does not depend on choices of (S, ϕ, \mathbf{a}) and J_{HF} . This is not true in general. For example, consider the closed contact 3-manifold where the contact structure is supported by the open book decomposition (S, ϕ) , where S is a 4-holed sphere and ϕ is the product of Dehn twists depicted in Figure 2, left. Using the basis of arcs \mathbf{a} shown in Figure 2, left, and a generic split almost complex structure J_{HF} , we observe that the shaded domain \mathcal{D} in Figure 2, right, has a unique holomorphic representative up to translation (see [49, Lemma 3.4]), and this is sufficient for the vanishing of the Ozsváth–Szabó contact class. A simple computation shows that $J_+(\mathcal{D}) = 2$. Therefore, \vec{x}_ξ represents the trivial class in $E^2(S, \phi, \mathbf{a}; J_{HF})$, and $o(S, \phi, \mathbf{a}; J_{HF}) \leq 1$. Furthermore, using the symmetry of the

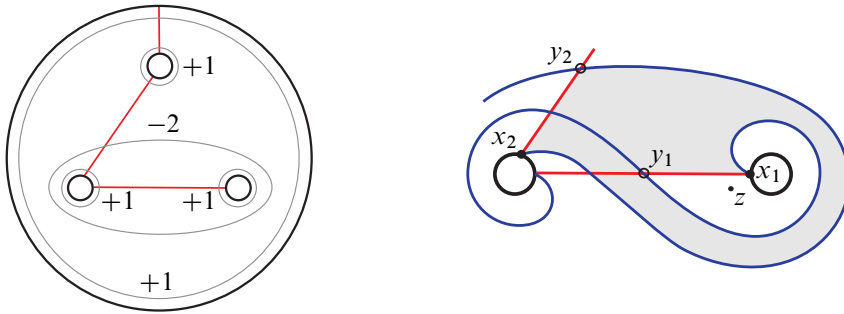

Figure 2: Left: an open book decomposition (S, ϕ) supporting an overtwisted contact structure and a basis of arcs depicted in red. Right: a Maslov index-1 holomorphic domain with $J_+ = 2$ in the $S \times \{0\}$ half of the Heegaard diagram $(-\Sigma, \alpha, \beta)$.

open book decomposition and the choice of the arc basis, one can argue as in [31] that $o(S, \phi, \mathbf{a}; J_{HF}) = 1$. However, the contact structure supported by the open book decomposition (S, ϕ) is overtwisted, which can be seen after a sequence of positive stabilizations to reveal the overtwisted disk (see [55] for an explicit algorithm). Then there exists another open book decomposition (S', ϕ') and a basis of arcs \mathbf{a}' on S' for which $o(S', \phi', \mathbf{a}'; J'_{HF}) = 0$ using a generic split almost complex structure J'_{HF} (see the proof of Theorem 2.3). As a result, o is not independent of these choices.

Definition 2.2 Let (M, ξ) be a closed contact 3-manifold. Then define the *spectral order*

$$o(M, \xi) := \min\{o(S, \phi, \mathbf{a}; J_{HF})\},$$

where the minimum is taken over all data $(S, \phi, \mathbf{a}; J_{HF})$ such that (S, ϕ) is an open book decomposition of M supporting ξ , \mathbf{a} is a collection of pairwise disjoint properly embedded arcs on S that contains a basis, and J_{HF} is a generic almost complex structure on $\Sigma \times [0, 1] \times \mathbb{R}$ satisfying conditions (J1)–(J5) in [35, Section 1].

It follows immediately that Definition 2.2 yields an invariant of contact structures. With the definition of our contact invariant in place, the first bullet point of Theorem 1.1 follows without much effort:

Theorem 2.3 Let ξ_{OT} be an overtwisted contact structure on a closed 3-manifold M . Then $o(M, \xi_{OT}) = 0$.

Proof Note that an overtwisted contact structure is supported by an open book decomposition (S, ϕ) where the monodromy ϕ is not right-veering [21, Theorem 1.1].

One can find a basis of arcs \mathbf{a} on S such that, in the corresponding Heegaard diagram, $\widehat{\partial}_{HF} \vec{y} = \vec{x}_{\xi_{OT}}$, where $\mathbf{y} = \{y_1, x_2, \dots, x_G\}$ and there is exactly one Maslov index-1 holomorphic domain \mathcal{D} , a bigon, that contributes to the differential [23, Lemma 3.2] as defined by a split complex structure on $\Sigma \times [0, 1] \times \mathbb{R}$. Therefore, $n_{\mathbf{y}}(\mathcal{D}(A)) = \frac{1}{4}$, $n_{\mathbf{x}_{\xi_{OT}}}(\mathcal{D}) = \frac{1}{4}$, $|\mathbf{y}| = G$ and $|\mathbf{x}_{\xi_{OT}}| = G$. Applying (2-6), we find $J_+(\mathcal{D}) = 0$. As a result, $o(M, \xi_{OT}) = 0$. □

3 Dependence on choices

This section investigates the question of dependence of $o(S, \phi, \mathbf{a}; J_{HF})$ on a choice of generic almost complex structure J_{HF} on $\Sigma \times [0, 1] \times \mathbb{R}$, where $\Sigma = S \times \{\frac{1}{2}\} \cup_{\partial S} S - S \times \{0\}$, a choice of the monodromy ϕ in its isotopy class, and how it changes under certain modifications of arc collections. We start with a priori dependence of o on a choice of generic almost complex structure.

3.1 Independence of almost complex structures

Proposition 3.1 *Fix an open book decomposition (S, ϕ) of M supporting ξ and a collection of pairwise disjoint properly embedded arcs \mathbf{a} on S that contains a basis. Suppose that (S, ϕ, \mathbf{a}) yields an admissible Heegaard diagram, and let J_{HF}^0 and J_{HF}^1 be two generic almost complex structures on $\Sigma \times [0, 1] \times \mathbb{R}$ satisfying conditions (J1)–(J5) in [35, Section 1]. Then $o(S, \phi, \mathbf{a}; J_{HF}^0) = o(S, \phi, \mathbf{a}; J_{HF}^1)$.*

Proof There exists a smooth 1-parameter family of \mathbb{R} -invariant almost complex structures $\{J_{HF}^s\}_{s \in \mathbb{R}}$ on $\Sigma \times [0, 1] \times \mathbb{R}$ that agrees with J_{HF}^0 if $s < \epsilon$ and with J_{HF}^1 if $s > 1 - \epsilon$ for some $\epsilon \ll 1$. As is explained in [35, Section 9], this family of almost complex structures can be chosen to satisfy conditions (J1), (J2) and (J4) in [35, Section 1] when considered as a non- \mathbb{R} -invariant almost complex structure on $\Sigma \times [0, 1] \times \mathbb{R}$. Furthermore, this almost complex structure guarantees transversality for pseudoholomorphic curves with prescribed boundary conditions. It is used in [35, Section 9] to define a chain map

$$\Phi: (\widehat{CF}(\Sigma, \boldsymbol{\beta}, \boldsymbol{\alpha}), \widehat{\partial}_{HF}^0) \rightarrow (\widehat{CF}(\Sigma, \boldsymbol{\beta}, \boldsymbol{\alpha}), \widehat{\partial}_{HF}^1)$$

via a signed count of J_{HF}^s -holomorphic curves in $\Sigma \times [0, 1] \times \mathbb{R}$ satisfying conditions (M0)–(M6) in [35, Section 1] and representing relative homology classes $A \in \widehat{\pi}_2(\vec{x}, \vec{y})$ with $\text{ind}(A) = 0$. If J_{HF}^s is generic, then the moduli space of such J_{HF}^s -holomorphic curves representing a class $A \in \widehat{\pi}_2(\vec{x}, \vec{y})$ with $\text{ind}(A) = 0$ (resp. $\text{ind}(A) = 1$) is a smooth

orientable 0–dimensional (resp. 1–dimensional) manifold whose compactification in the 1–dimensional case is obtained by adding on pseudoholomorphic buildings of height 2 in which one level is J_{HF}^s –holomorphic and the other is either J_{HF}^0 –holomorphic or J_{HF}^1 –holomorphic as the case may be. The topology of the curves in each component of these moduli spaces is fixed.

Now we define an integer-valued function on moduli spaces of J_{HF}^s –holomorphic curves in $\Sigma \times [0, 1] \times \mathbb{R}$ with $\text{ind} \leq 1$ satisfying conditions (M0)–(M6) in [35, Section 1]. If C_L is such a curve representing a class in $\hat{\pi}_2(\vec{x}, \vec{y})$, then define

$$(3-1) \quad J_+(C_L) := -\chi(C_L) + N + |\mathbf{x}| - |\mathbf{y}|.$$

Note that (3-1) is additive in the sense that, if a pseudoholomorphic building of height 2 consists of a J_{HF}^0 –holomorphic curve C_L^1 with $\text{ind} = 1$ representing a class in $\hat{\pi}_2(\vec{x}, \vec{x}')$ and a J_{HF}^s –holomorphic curve C_L^0 with $\text{ind} = 0$ representing a class in $\hat{\pi}_2(\vec{x}', \vec{y})$, then the J_{HF}^s –holomorphic curve C_L obtained from these by gluing (see [35, Appendix A]) satisfies

$$(3-2) \quad J_+(C_L) = J_+(C_L^1) + J_+(C_L^0),$$

since $\chi(C_L) = \chi(C_L^1) + \chi(C_L^0) - N$. The same holds for a pseudoholomorphic building of height 2 consisting of a J_{HF}^s –holomorphic curve C_L^0 with $\text{ind} = 0$ representing a class in $\hat{\pi}_2(\vec{x}, \vec{y}')$ and a J_{HF}^1 –holomorphic curve C_L^1 with $\text{ind} = 1$ representing a class in $\hat{\pi}_2(\vec{y}', \vec{y})$. Note also that (3-1) coincides with (2-4), which allows us to deduce similarly that $J_+(C_L)$ is a nonnegative even integer. Hence, we may decompose Φ as

$$\Phi = \Phi^0 + \Phi^1 + \dots + \Phi^l + \dots,$$

where Φ^l counts J_{HF}^s –holomorphic curves with $J_+ = 2l$. Since Φ is a chain map and J_+ is additive under gluing, it follows that

$$\sum_{i+j=l} (\Phi^i \circ \partial_j^0 - \partial_i^1 \circ \Phi^j) = 0.$$

This identity implies that there is a filtered chain map $\hat{\Phi}$ from $(\widehat{\mathcal{CF}}(S, \phi, \mathbf{a}), \hat{\partial}^0)$ to $(\widehat{\mathcal{CF}}(S, \phi, \mathbf{a}), \hat{\partial}^1)$ defined by

$$\hat{\Phi} \left(\sum_{i \in \mathbb{Z}} c_i t^i \right) := \sum_{i \in \mathbb{Z}} \left(\sum_{l \in \mathbb{Z}} (\Phi^l c_i) t^{i-l} \right),$$

and hence a morphism of spectral sequences from $E^*(S, \phi, \mathbf{a}; J_{HF}^0)$ to $E^*(S, \phi, \mathbf{a}; J_{HF}^1)$. Moreover, $\Phi(\vec{x}_\xi) = \vec{x}_\xi$ since the only J_{HF}^s –holomorphic curve with negative ends at \vec{x}_ξ satisfying conditions (M0)–(M6) in [35, Section 1] is $\vec{x}_\xi \times \mathbb{R}$. Therefore, we

have $o(S, \phi, \mathbf{a}; J_{HF}^0) \geq o(S, \phi, \mathbf{a}; J_{HF}^1)$. On the other hand, we may also consider the chain map induced by the smooth 1-parameter family of almost complex structures $\{J_{HF}^{1-s}\}_{s \in \mathbb{R}}$. Likewise, we obtain $o(S, \phi, \mathbf{a}; J_{HF}^0) \leq o(S, \phi, \mathbf{a}; J_{HF}^1)$. As a result, $o(S, \phi, \mathbf{a}; J_{HF}^0) = o(S, \phi, \mathbf{a}; J_{HF}^1)$. \square

3.2 Isotopy independence

Given Proposition 3.1, we may drop a choice of generic almost complex structure from the notation and simply write $o(S, \phi, \mathbf{a})$. We proceed to discuss the dependence of o on the monodromy. In this regard, let ϕ and ϕ' be two orientation-preserving diffeomorphisms of S that restrict to the identity in a neighborhood of ∂S . Suppose that ϕ is isotopic to ϕ' , and fix an isotopy $\{\phi_t\}_{t \in [0,1]}$ relative to ∂S such that $\phi_0 = \phi$ and $\phi_1 = \phi'$. Given a collection of pairwise disjoint properly embedded arcs \mathbf{a} on S that contains a basis, the isotopy $\{\phi_t\}_{t \in [0,1]}$ yields an isotopy of arcs $\{\phi_t(\mathbf{b})\}_{t \in [0,1]}$, where \mathbf{b} is the collection of arcs as in Section 2.1. Of interest to us are two kinds of isotopies:

- (1) For any $t \in [0, 1]$, \mathbf{a} intersects $\phi_t(\mathbf{b})$ transversally in the interior of S .
- (2) The isotopy creates/annihilates a pair of transverse intersections between \mathbf{a} and $\phi(\mathbf{b})$.

Following [35], we refer to such isotopies as *basic isotopies*. In general, a pointed isotopy between two multipointed Heegaard diagrams, namely an isotopy supported in the complement of the basepoints, is called *admissible* if each intermediate multipointed Heegaard diagram is admissible. Any two admissible multipointed Heegaard diagrams that are pointed isotopic are in fact isotopic through a sequence of admissible basic isotopies (see [35, Proposition 5.6]). Note that isotopies of the monodromy of an open book decomposition yield pointed isotopies of the corresponding multipointed Heegaard diagram. Therefore, it suffices to investigate the behavior of o under admissible basic isotopies of the monodromy.

Proposition 3.2 *Let (S, ϕ) be an open book decomposition and \mathbf{a} be a collection of pairwise disjoint properly embedded arcs \mathbf{a} on S that contains a basis. Suppose that (S, ϕ, \mathbf{a}) yields an admissible multipointed Heegaard diagram and that ϕ' is isotopic to ϕ via an admissible basic isotopy. Then $o(S, \phi', \mathbf{a}) = o(S, \phi, \mathbf{a})$.*

Proof As is explained in [35, Chapter 9] (see also [48, Section 7.3]), basic isotopies of the first kind above are equivalent to deformations of the complex structure on Σ .

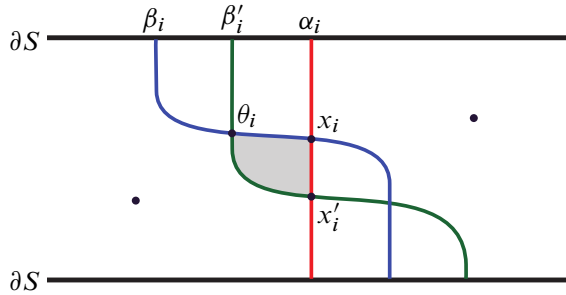

Figure 3: Part of the restriction of the multipointed Heegaard triple diagram $(\Sigma, \beta', \beta, \alpha, z)$ to $S \times \{\frac{1}{2}\} \subset \Sigma$.

With this understood, o is unchanged under isotopies of this sort by Proposition 3.1. As for basic isotopies of the second kind above, we consider the chain maps induced by the multipointed Heegaard triple diagram $(\Sigma, \beta', \beta, \alpha, z)$, where $\beta' = \{\beta'_1, \dots, \beta'_N\}$ is such that each β'_i is obtained from a small Hamiltonian isotopy of $a_i \cup \phi'(b_i)$ so that it intersects β_i transversally in exactly two points near the point x_i , as shown in Figure 3, while it is disjoint from β_j for $j \neq i$. As a result, the Heegaard diagram (Σ, β', β) represents the manifold $\#_G S^1 \times S^2$, where G is the genus of Σ ; we may assume that the signed area of the region between β and β' is zero with respect to an area form on Σ which delivers the admissibility criteria for the multipointed Heegaard diagram $(\Sigma, \beta', \beta, z)$ as stated in [35, Lemma 5.3]. Consequently, the multipointed Heegaard triple diagram $(\Sigma, \beta', \beta, \alpha, z)$ is also admissible by [35, Lemma 10.14].

The Heegaard triple diagram $(\Sigma, \beta', \beta, \alpha)$ describes a cobordism with one outgoing boundary component and two incoming boundary components, one of which is diffeomorphic to the manifold $\#_G S^1 \times S^2$. To be more specific, this cobordism is diffeomorphic to the complement of a tubular neighborhood of a bouquet of G embedded circles in the product cobordism $[0, 1] \times M$. It follows that there is a unique Spin^c structure \mathfrak{t}_ξ on this cobordism which restricts to the trivial Spin^c structure \mathfrak{s}_o on $\#_G S^1 \times S^2$ and to \mathfrak{s}_ξ on M .

With the preceding understood, there exists a chain map

$$\hat{f}_{\beta', \beta, \alpha; \mathfrak{t}_\xi} : \widehat{CF}(\Sigma, \beta', \beta, \mathfrak{s}_o) \otimes_{\mathbb{F}} \widehat{CF}(\Sigma, \beta, \alpha, \mathfrak{s}_\xi) \rightarrow \widehat{CF}(\Sigma, \beta', \alpha, \mathfrak{s}_\xi),$$

defined by counting embedded Fredholm index-0 pseudoholomorphic curves in $\Sigma \times T$ subject to appropriate boundary conditions. Here T denotes a disk with three marked points on its boundary and $\Sigma \times T$ is equipped with an almost complex structure satisfying conditions $(J'1)$ – $(J'4)$ in [35, Section 10.2, page 1018].

No matter the almost complex structure, the differential on $\widehat{CF}(\Sigma, \beta', \beta, s_0)$ vanishes identically. Therefore, restricting to the subcomplex $\mathbb{F} \cdot \vec{\theta} \otimes_{\mathbb{F}} \widehat{CF}(\Sigma, \beta, \alpha, s_\xi)$, where $\theta = \{\theta_1, \dots, \theta_N\}$ and $\vec{\theta}$ is the top degree generator of $\widehat{CF}(\Sigma, \beta', \beta, s_0)$, results in a chain map

$$\hat{f}_{\beta', \beta, \alpha; t_\xi}(\vec{\theta} \otimes \cdot) : \widehat{CF}(\Sigma, \beta, \alpha, s_\xi) \rightarrow \widehat{CF}(\Sigma, \beta', \alpha, s_\xi).$$

The latter induces an isomorphism of homologies by [35, Proposition 11.4] (see also [48, Proposition 9.8]). In what follows, we work with a generic split complex structure on $\Sigma \times T$. We are allowed to do so since transversality of moduli spaces as defined by such almost complex structures can be guaranteed by slight perturbation of the α -, β - and β' -curves. To be more precise, we may invoke the technique of [46]. This is because any class A in $\widehat{\pi}_2(\vec{\theta}, \cdot, \cdot)$ satisfies the boundary injectivity criterion in the sense of [35]. By way of a reminder, a class A in $\widehat{\pi}_2(\vec{\theta}, \cdot, \cdot)$ is said to satisfy the boundary injectivity criterion if any pseudoholomorphic curve u for some split complex structure on $\Sigma \times T$ representing the class A has $\pi_\Sigma \circ u$ somewhere injective in its boundary. This criterion is guaranteed as long as the domain representing the class has a region with multiplicity one adjacent to a region of multiplicity zero. Note that this is the case for any class in $\widehat{\pi}_2(\vec{\theta}, \cdot, \cdot)$ due to the placement of the basepoints, in that basepoints appear on both sides of every α -, β - and β' -curve.

Next we show that the chain map $\hat{f}_{\beta', \beta, \alpha; t_\xi}(\vec{\theta} \otimes \cdot)$ induces a morphism of spectral sequences from $E^*(S, \phi, \mathbf{a}; J_{HF})$ to $E^*(S, \phi', \mathbf{a}; J'_{HF})$. First, define an analog of (2-1) for the cobordism described by the Heegaard triple diagram $(\Sigma, \beta', \beta, \alpha)$ via

$$(3-3) \quad J_+(A) = \frac{1}{2}N + \mu(\mathcal{D}(A)) - 2e(A) + |x| - |y|,$$

where $A \in \widehat{\pi}_2(\vec{\theta}, \vec{x}, \vec{y})$; $\mu(\mathcal{D}(A))$ denotes the Maslov index of the domain $\mathcal{D}(A)$ associated to A , which is the expected dimension of the moduli space of pseudoholomorphic curves representing the class A ; and $e(A)$ is the Euler measure of the domain associated to the class A . If A can be represented by an embedded Fredholm index-0 pseudoholomorphic curve C_L , then (3-3) becomes

$$J_+(A) = \frac{1}{2}N - 2e(A) + |x| - |y| = \underbrace{-\chi(C_L) + N}_{\text{by [35, Section 10.2]}} + |x| - |y|.$$

It follows from this formula that $J_+(A) = 2l$ for some $l \geq 0$. To see this, consider the smooth compact oriented surface C obtained from the compactification of C_L by first adding 2-dimensional 1-handles, one for each pair (β'_i, β_i) and one for each pair (β'_i, α_i) , and then capping off the boundary components of the resulting surface

containing the I -chord collection $\vec{\theta}$. Note that $\chi(C) = \chi(C_L) - N$, and $|x|$ (resp. $|y|$) is equal to the number of boundary components of C arising from the I -chord collection \vec{x} (resp. \vec{y}). The claim then follows in exactly the same way as in Section 2. Consequently, we can decompose the chain map $\hat{f}_{\beta', \beta, \alpha; t_\xi}(\vec{\theta} \otimes \cdot)$ as

$$\hat{f}_{\beta', \beta, \alpha; t_\xi}(\vec{\theta} \otimes \cdot) = f^0 + f^1 + \dots + f^l + \dots,$$

where f^l counts embedded Fredholm index-0 pseudoholomorphic curves with $J_+ = 2l$. Since the Maslov index and the Euler measure are additive under concatenation, it follows using (2-1) and (3-3) that J_+ is also additive. Therefore, we have

$$(3-4) \quad \sum_{i+j=l} (f^i \circ \partial_j - \partial'_i \circ f^j) = 0$$

since $\hat{f}_{\beta', \beta, \alpha; t_\xi}$ is a chain map and the J_+ -filtered differential on $\widehat{CF}(\Sigma, \beta', \beta, s_o)$ is identically zero. The latter is due to the fact that $\widehat{CF}(\Sigma, \beta', \beta, s_o)$ is isomorphic to $(\mathbb{F}_{(0)} \oplus \mathbb{F}_{(1)})^{\otimes N}$, where $\mathbb{F}_{(0)} \oplus \mathbb{F}_{(1)}$ is a graded module over \mathbb{F} with vanishing differential and the domains corresponding to the pseudoholomorphic curves that contribute to the differential of the generator, $\theta_i \times [0, 1]$, of $\mathbb{F}_{(1)}$ are both bigons, which have $J_+ = 0$. In short, the restriction of the differential on $\widehat{CF}(\Sigma, \beta', \beta, s_o) \otimes_{\mathbb{F}} \widehat{CF}(\Sigma, \beta, \alpha, s_\xi)$ to the subcomplex $\mathbb{F} \cdot \vec{\theta} \otimes_{\mathbb{F}} \widehat{CF}(\Sigma, \beta, \alpha, s_\xi)$ is J_+ -filtered.

The identity (3-4) implies that there is a filtered chain map from $(\widehat{CF}(S, \phi, \mathbf{a}), \hat{\partial})$ to $(\widehat{CF}(S, \phi', \mathbf{a}), \hat{\partial}')$ as before, and hence a morphism of spectral sequences from $E^*(S, \phi, \mathbf{a}; J_{HF})$ to $E^*(S, \phi', \mathbf{a}; J'_{HF})$. In addition,

$$\hat{f}_{\beta', \beta, \alpha; t_\xi}(\vec{\theta} \otimes \vec{x}_\xi) = \vec{x}'_\xi$$

since the shaded triangles in Figure 3 constitute the only holomorphic domain that contributes to this chain map due to the placement of the basepoints, and it is represented by a unique pseudoholomorphic curve by the Riemann mapping theorem. Hence, $o(S, \phi, \mathbf{a}; J_{HF}) \geq o(S, \phi', \mathbf{a}; J'_{HF})$. Likewise, the isotopy from ϕ' to ϕ yields $o(S, \phi, \mathbf{a}; J_{HF}) \leq o(S, \phi', \mathbf{a}; J'_{HF})$. As a result, $o(S, \phi, \mathbf{a}; J_{HF}) = o(S, \phi', \mathbf{a}; J'_{HF})$. \square

Remark Sarkar and Wang [54] and Plamenevskaya [52] proved that the Heegaard diagram resulting from an arbitrary choice of (S, ϕ, \mathbf{a}) , where \mathbf{a} contains a basis, can be made *nice* by choosing ϕ appropriately in its isotopy class. On a nice Heegaard diagram, every Maslov index-1 holomorphic domain is represented by an *empty* embedded bigon or an *empty* embedded square [54, Theorem 3.3]. It is easy to see from (2-1) that such domains have either $J_+ = 0$ or $J_+ = 2$. This observation indicates that there should be a combinatorial description of o .

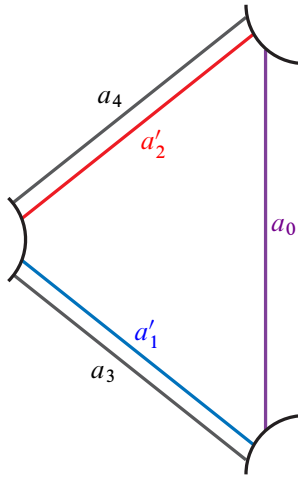

Figure 4: The configuration of arcs in the $S \times \{\frac{1}{2}\}$ page of the open book decomposition representing a triangle elimination operation.

3.3 Eliminating triangles

In this subsection, we investigate dependence of o on a choice of collection of pairwise disjoint properly embedded arcs containing a basis. More specifically, given an open book decomposition (S, ϕ) and such an arc collection \mathbf{a} on S , we prove that o is nonincreasing under a *triangle elimination* operation on \mathbf{a} , which we will describe in a moment. As we shall see in Section 4, this operation gives us quite a bit of flexibility in our arguments that lead to the proofs of our main theorems. To set the stage, let (S, ϕ) be an open book decomposition supporting a contact structure ξ , and $\mathbf{a} = \{a_0, a_3, a_4, \dots, a_N\}$ be a collection of pairwise disjoint properly embedded arcs on S that contains a basis. Suppose that the three arcs $a_0, a_3, a_4 \in \mathbf{a}$ bound a connected component of $S \setminus \bigcup \mathbf{a}$. Denote by \mathbf{a}' the collection of pairwise disjoint properly embedded arcs on S obtained by discarding a_0 and “doubling” a_3 and a_4 , ie $\mathbf{a}' = \{a'_1, a'_2, a_3, a_4, \dots, a_N\}$, where a'_1 and a'_2 are parallel and sufficiently close to a_3 and a_4 , respectively (see Figure 4). Then:

Proposition 3.3 *Let (S, ϕ) be an open book decomposition, \mathbf{a} be a collection of pairwise disjoint properly embedded arcs on S that contains a basis, and \mathbf{a}' be obtained from \mathbf{a} via triangle elimination. Then $o(S, \phi, \mathbf{a}') \leq o(S, \phi, \mathbf{a})$.*

In preparation for the proof of the above proposition, we assume that the monodromy ϕ moves the arcs a_0, a_3 and a_4 to the right, since otherwise it would not move a'_1

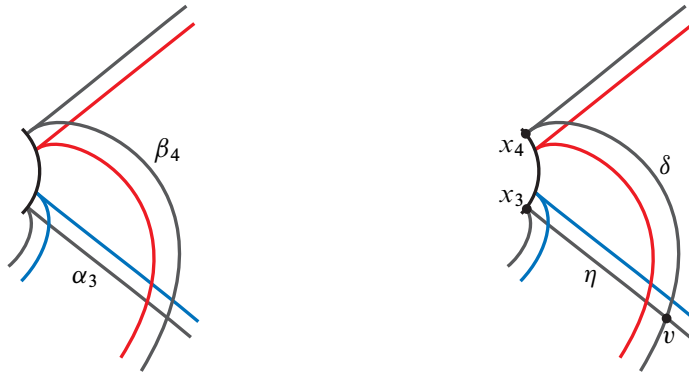

Figure 5: Left: the local behavior of the β -curves as shown in the $S \times \{0\}$ half of the Heegaard diagram $(\Sigma, \beta', \alpha')$. Right: the arc configuration in the desired nice Heegaard diagram with the arcs prohibited from forming bigons indicated.

and a'_2 to the right either, resulting in both $o(S, \phi, \mathbf{a})$ and $o(S, \phi, \mathbf{a}')$ being zero as in the proof of Theorem 2.3. We further assume that β_4 stays parallel to the boundary of S immediately after turning right in the $S \times \{0\}$ half of the Heegaard diagram

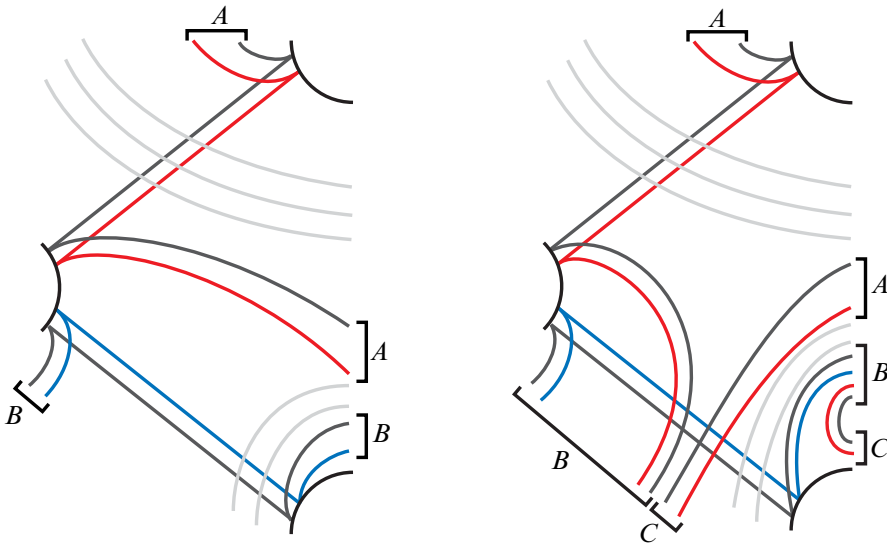

Figure 6: Left: configuration of arcs when β_4 doesn't stay parallel to the boundary of S immediately after turning right in the $S \times \{0\}$ half of the Heegaard diagram. Right: configuration of arcs after an isotopy to guarantee that β_4 intersects α_3 immediately after turning right. In both figures, brackets indicate the ends of arcs that are identified.

until it intersects α_3 as in Figure 5, left. Otherwise (see Figure 6, left), isotope the monodromy ϕ so as to guarantee that this is the case (see Figure 6, right). Note that, by Proposition 3.2, o is invariant under isotopies of the monodromy ϕ . With the preceding understood, we prove that we can work with a special kind of *nice* Heegaard diagram after a sequence of isotopies of the monodromy.

Lemma 3.4 *We may isotope the monodromy ϕ so that the multipointed Heegaard diagram $(\Sigma, \beta', \alpha', z')$ corresponding to (S, ϕ, \mathbf{a}') is nice while making sure that the intersection pattern as depicted in Figure 5, left, is preserved.*

Proof As is argued in [52], we may apply the algorithm of Sarkar and Wang [54, Section 4.1] to produce a nice Heegaard diagram by performing finger moves on β -curves only in the $S \times \{0\}$ half of the Heegaard surface Σ . This is because, in a Heegaard diagram arising from an open book decomposition, there are regions with basepoints on either side of every β -curve. In order to preserve the intersection pattern in Figure 5, left, we will show that these finger moves on β -curves can be performed in such a way that the arc δ along β_4 between the points x_4 and v , shown in Figure 5, right, remains unchanged, and, in the resulting nice Heegaard diagram, no β -curve forms a bigon with the arc η along α_3 between the points x_3 and v . It suffices to perform these finger moves in the Heegaard diagram resulting from the arc collection $\{a_3, a_4, \dots, a_N\}$, which still contains a basis, since adding a'_1 and a'_2 , parallel to a_3 and a_4 , respectively, merely subdivides bigon and rectangle regions into smaller bigon and rectangle regions. With the preceding understood, we produce a nice diagram with the desired properties in the three steps that follow. Throughout, we change the definition of the *distance* of a region used in the Sarkar–Wang algorithm to be the minimum number of intersection points between the β -curves and an arc connecting the interior of that region to a region with basepoint, with the arc taken to be in the complement of the α -curves and the arc δ .

Step 1 Note that, given a region, there is exactly one region with basepoint that can be connected to the interior of that region via an arc in the complement of the α -curves and the arc δ . Proceed as in the algorithm of Sarkar and Wang by first killing all nondisk regions without performing a finger move starting at δ and then performing finger moves as in the proof of [54, Lemma 4.1] to reduce the *distance d complexity* of the Heegaard diagram to (0) starting from *bad regions* with the largest distance. By way of reminder, the badness of a $2n$ -gon is defined in [54, Section 4.1] to be $\max\{n - 2, 0\}$,

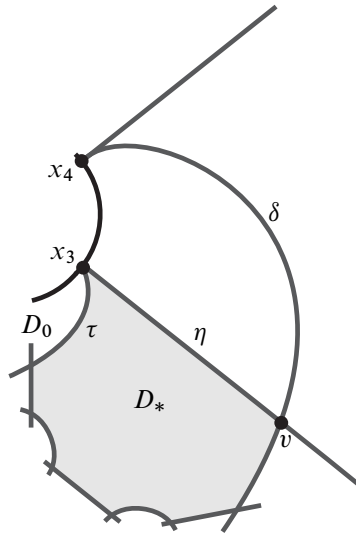

Figure 7: The domain D_* , the adjacent region with basepoint D_0 , and the arc τ along β_3 which they both have on their boundaries.

and the distance d complexity of a multipointed Heegaard diagram is the tuple

$$\left(\sum_{i=1}^m b(D_i), -b(D_1), \dots, -b(D_m) \right),$$

where D_1, \dots, D_m are all the distance d bad regions ordered in decreasing measure of badness $b(D_1) \geq \dots \geq b(D_m)$. Given a distance d bad region, a finger move used to break up that region into regions of smaller badness as in the proof of [54, Lemma 4.1] starts from an arc along a β -curve that is common to that bad region and another region of distance $d - 1$. As a result of our definition of the distance of a region, the region without a basepoint that has the arc δ on its boundary is adjacent to a region with distance one less along an arc along a β -curve other than δ . Therefore, at no point in the process do the finger moves needed to break up the former region into rectangles and bigons start at δ . Continue performing finger moves as in the proof of [54, Lemma 4.1] until the *distance* of the Heegaard diagram is reduced to 1; that is, until all bad regions are of distance at most 1.

Step 2 Having completed Step 1, all bad regions now have distance at most 1. The region with no basepoints and the arc η on its boundary has distance 1, and it is adjacent to a region with basepoint D_0 along β_3 (see Figure 7). Denote this region by D_* . The goal of this step is to break up every bad region except for D_* , if it is a bad region

at any point during the process, into rectangles and bigons, while avoiding crossing the arc η . Perform finger moves as in the proof of [54, Lemma 4.1], ignoring D_* in the measure of distance 1 complexity of the Heegaard diagram and stopping all finger moves once they enter D_* . Doing so breaks up every bad region other than D_* into rectangles and bigons and preserves the intersection pattern in Figure 5, left. We can do this because the Sarkar–Wang algorithm terminates after a finite number of finger moves, and we can stop those finger moves that enter D_* once they enter D_* . This modification of the algorithm does not increase the distance of any bad regions, and the modified algorithm eventually breaks up every bad region other than D_* into rectangles and bigons at the expense of possibly increasing the badness of D_* . The proof of the lemma is complete if D_* is not a bad region at the end of this step. Otherwise, we proceed to Step 3 in order to break up D_* into rectangles and bigons without changing badness of any other region without a basepoint.

Step 3 Finally, we break up the only remaining bad region, namely, D_* . We claim that we can perform a sequence of finger moves as in the proof of [54, Lemma 4.1] so that, in the resulting nice Heegaard diagram, no β -curve forms a bigon with η . We prove this claim by strong induction on the badness $b(D_*)$ of the region D_* . If $b(D_*) = 1$ — that is, if D_* is a hexagon — then performing a finger move as in the proof of [54, Lemma 4.1] starting at the arc τ along β_3 with an end at x_3 on the boundary of D_* breaks D_* up into two rectangles. Moreover, since all other regions are either bigons or rectangles, this finger has to push through a “tunnel” of rectangular regions, forcing it to stay “parallel” to a β -curve. Therefore, it won’t come back to D_* , since otherwise it would have to follow a full β -curve, which in turn would force our finger to cross a region with basepoint because there are regions with basepoint on either side of every β -curve. Next suppose that $b(D_*) > 1$ and perform a finger move as in the proof of [54, Lemma 4.1] starting at τ (see Figure 8, left). If the finger doesn’t come back to D_* , then it will end up in a bigon region or a region with basepoint, and D_* will be broken up into a region $D_{*,1}$ with badness $b(D_*) - 1$ and a rectangle $D_{*,2}$. Note that both $D_{*,1}$ and $D_{*,2}$ are adjacent to D_0 along β_3 , and that $D_{*,1}$ has the arc η on its boundary (see Figure 8, right). Then, by the induction hypothesis, the claim is true. Suppose instead that the finger comes back to D_* . Then, by the argument in [54, Subcase 4.2] and the fact that there are regions with basepoint on either side of every β -curve, there exists another finger move starting at τ that doesn’t come back to D_* . This finger move would break D_* up into two regions, $D_{*,1}$ and $D_{*,2}$, both adjacent to D_0 along β_3 and $D_{*,1}$ having the arc η on its boundary. Then we have $b(D_{*,1}) + b(D_{*,2}) = b(D_*) - 1$

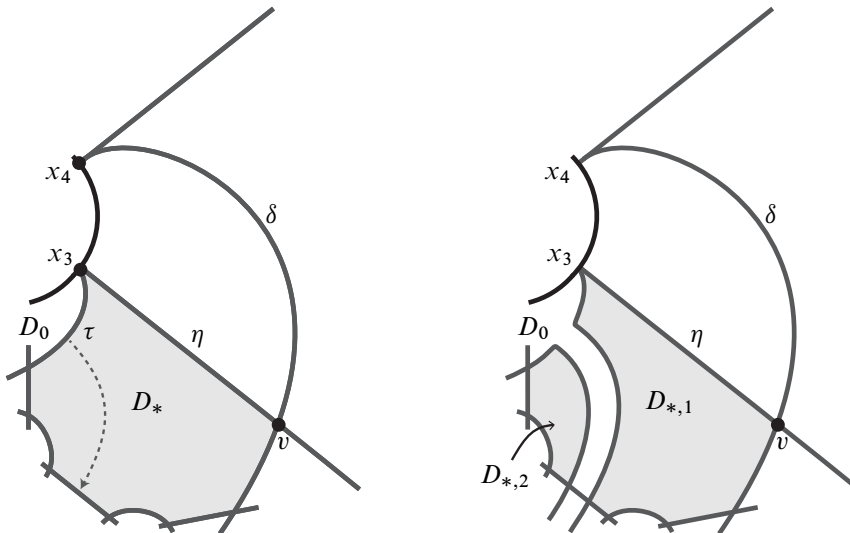

Figure 8: Left: the dashed line indicates the finger move to break up D_* . Right: the regions $D_{*,1}$ and $D_{*,2}$ formed after the finger move.

and $b(D_{*,2}) \geq 1$. Once again, in contrast to the Sarkar–Wang algorithm, which requires ordering bad regions with increasing badness and then breaking up bad regions starting with the regions having the least positive badness, we first break up the region $D_{*,2}$ regardless of whether it is a bad region with the least positive badness. As we perform finger moves to break up $D_{*,2}$, as well as any subsequent new bad region that might emerge in that process, we stop a finger move that enters $D_{*,1}$ once it enters $D_{*,1}$, regardless of whether $b(D_{*,1}) > 0$ or not. In order to break up a bad region with badness b into rectangles, we need to perform exactly b finger moves, assuming no finger comes back to that region, and each finger pushed into a region would increase its badness by 1. Therefore, the process of breaking up $D_{*,2}$ into rectangles would increase the badness of $D_{*,1}$ by at most $b(D_{*,2})$. In the end, we have a Heegaard diagram with a single bad region of distance 1 adjacent to D_0 along τ having the arc η on its boundary. The badness of this region is at most $b(D_{*,1}) + b(D_{*,2}) = b(D_*) - 1$. Hence, by the induction hypothesis, our claim holds true, and a further sequence of finger moves as described above yields the desired nice Heegaard diagram. \square

With the above lemma understood, isotope a_0 and ϕ so that α_0 and β_0 intersect β_4 and α_3 , respectively, to form bigons as in Figure 9, left. Then the multipointed Heegaard diagram $(\Sigma, \boldsymbol{\beta}, \boldsymbol{\alpha}, \mathbf{z})$ corresponding to (S, ϕ, \mathbf{a}) is also nice. This is because outside the shaded areas in Figure 9, center and right, the multipointed Heegaard diagrams

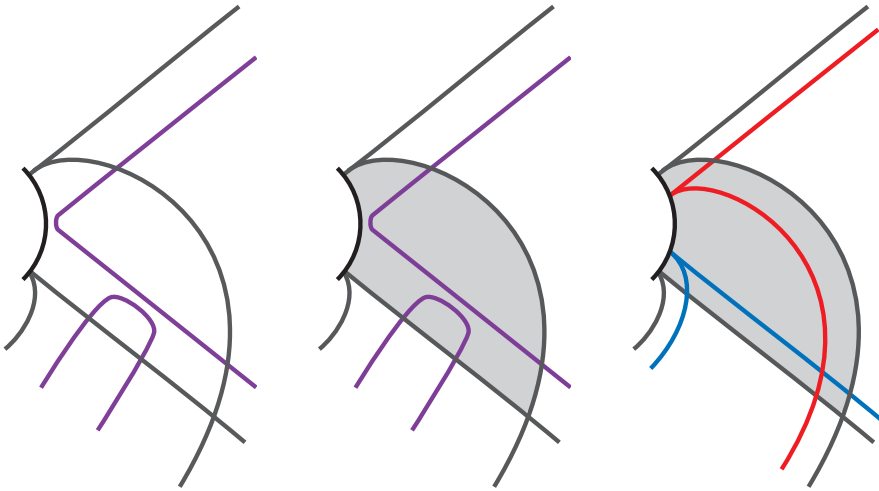

Figure 9: Left: the $S \times \{0\}$ half of the multipointed Heegaard diagram $(\Sigma, \beta, \alpha, z)$. Center and right: the shaded areas in which the regions in the two multipointed Heegaard diagrams $(\Sigma, \beta, \alpha, z)$ and $(\Sigma, \beta', \alpha', z')$ essentially differ.

$(\Sigma, \beta, \alpha, z)$ and $(\Sigma, \beta', \alpha', z')$, respectively, are isomorphic and, in the shaded area in Figure 9, center, all regions without a basepoint in $(\Sigma, \beta, \alpha, z)$ are bigons. Since o is invariant under isotopy of ϕ , we may assume without loss of generality that the monodromy ϕ is such that the multipointed Heegaard diagrams $(\Sigma, \beta, \alpha, z)$ and $(\Sigma, \beta', \alpha', z')$ are both nice and have the intersection patterns depicted in Figures 5, left, and 9, left. Note also that, in the multipointed Heegaard diagram $(\Sigma, \beta, \alpha, z)$, no α -curve other than α_0 forms a bigon with δ and no β -curve other than β_0 forms a bigon with η .

Proof of Proposition 3.3 To start, associate to each $(N-1)$ -tuple of intersection points $y = \{y_0, y_3, y_4, \dots, y_N\}$ defining a generator \vec{y} of $\widehat{CF}(\Sigma, \beta, \alpha)$ a unique $(N-1)$ -tuple of intersection points y' in $\alpha' \cap \beta'$ using the following recipe. For points belonging to y that lie on α_0 or β_0 , associate a unique point in $\alpha' \cap \beta'$ according to the following rules:

- If $y_0 \in \alpha_0 \cap \beta_0$ and $y_0 \neq x_0$, then the associated point in $\alpha' \cap \beta'$ lies in $\alpha'_i \cap \beta'_j$, where $i, j \in \{1, 2\}$ (see Figure 10, left). If $y_0 = x_0$, we associate to it the point x'_1 .
- If $y_0 \in \alpha_0 \cap \beta_j$ with $j \geq 3$, then the associated point in $\alpha' \cap \beta'$ lies in $\alpha'_i \cap \beta_j$, where $i \in \{1, 2\}$ (see Figure 10, center).
- If $y_i \in \alpha_i \cap \beta_0$ with $i \geq 3$, then the associated point in $\alpha' \cap \beta'$ lies in $\alpha_i \cap \beta'_j$, where $j \in \{1, 2\}$ (see Figure 10, right).

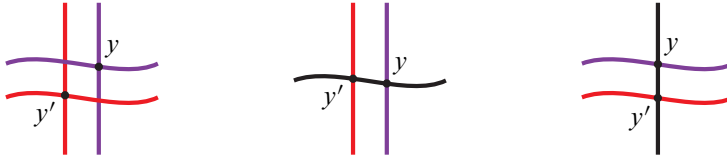

Figure 10: Assigning to an intersection point in $\alpha \cap \beta$ an intersection point in $\alpha' \cap \beta'$. Straight arcs indicate α -curves, while wavy arcs indicate β -curves. Purple corresponds to α_0 or β_0 , black corresponds to α_i or β_j for $i, j \geq 3$, and red corresponds to α'_i or β'_j for $i, j \in \{1, 2\}$.

In all other cases, the intersection points remain the same. Note that y' uses exactly one of α'_1 or α'_2 , and exactly one of β'_1 and β'_2 . Depending on which pair of α'_i and β'_j that y' uses, we assign y the ordered pair $p_y := (i, j)$. Then, unless $p_y = (1, 2)$, we associate to y a unique N -tuple of intersection points $\tilde{y} := \{y'_1, y'_2, y'_3, y'_4, \dots, y'_N\}$ defining a generator \vec{y} of the chain complex $\widehat{CF}(\Sigma, \beta', \alpha')$ by adding to y'

- the point x'_2 if $p_y = (1, 1)$,
- the point $w \in \alpha'_1 \cap \beta'_2$ indicated in Figure 11 if $p_y = (2, 1)$,
- the point x'_1 if $p_y = (2, 2)$.

Note that this recipe associates to the distinguished $(N-1)$ -tuple of intersection points $x_\xi = \{x_0, x_3, x_4, \dots, x_N\}$ the distinguished N -tuple of intersection points

$$x'_\xi = \{x'_1, x'_2, x_3, x_4, \dots, x_N\}.$$

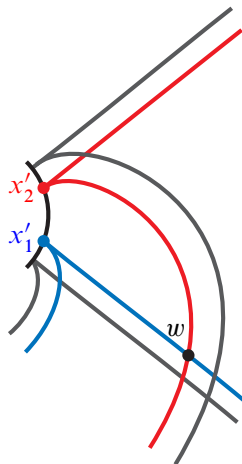

Figure 11: The intersection point w .

These two sets of intersection points define the distinguished generators that represent the Ozsváth–Szabó contact class in the homology of the chain complexes $\widehat{CF}(\Sigma, \beta, \alpha)$ and $\widehat{CF}(\Sigma, \beta', \alpha')$, respectively.

Lemma 3.5 *Let $\mathcal{D} \in \widehat{\pi}_2(\vec{y}^1, \vec{y}^2)$ be a Maslov index-1 holomorphic domain. Then $p_{\mathbf{y}^1} = p_{\mathbf{y}^2}$ unless \mathcal{D} is a bigon. Furthermore, if $p_{\mathbf{y}^1} = (1, 2)$, then $p_{\mathbf{y}^2} = (1, 2)$.*

Proof Given $\mathbf{y}^1 = \{y_0^1, y_3^1, y_4^1, \dots, y_N^1\}$ defining a generator \vec{y}^1 of $\widehat{CF}(\Sigma, \beta, \alpha)$, the first entry of the ordered pair $p_{\mathbf{y}^1}$ is determined by y_0^1 , specifically by whether y_0^1 is near α'_1 or α'_2 . Similarly, the second entry of $p_{\mathbf{y}^1}$ is determined by $y_i^1 \in \alpha_i \cap \beta_0$, specifically by whether y_i^1 is near β'_1 or β'_2 . Let $\mathcal{D} \in \widehat{\pi}_2(\vec{y}^1, \vec{y}^2)$ be a rectangular Maslov index-1 domain and $p_{\mathbf{y}^1} = (i, j)$. If \mathcal{D} has neither an edge along α_0 nor an edge along β_0 on its boundary, then it follows at once from the definition of $p_{\mathbf{y}^1}$ that $p_{\mathbf{y}^2} = (i, j)$. If, on the other hand, \mathcal{D} has an edge along α_0 and/or an edge along β_0 on its boundary, but it does not overlap the shaded area in Figure 9, center, then \mathcal{D} has to have an edge parallel to α_3 or to α_4 depending on whether $i = 1$ or $i = 2$, and/or an edge parallel to β_3 or β_4 depending on whether $j = 1$ or $j = 2$ on its boundary; hence, $p_{\mathbf{y}^2} = (i, j)$. Finally, if \mathcal{D} has an edge along α_0 and/or an edge along β_0 on its boundary, and it overlaps the shaded area in Figure 9, center, then it has an edge along α_0 or along β_0 running parallel to both α_3 and α_4 or to both β_3 and β_4 , respectively, on its boundary. Such a rectangular domain would have to have an edge on its boundary along either another α_k or another β_k for some $k \geq 3$ running parallel to both α_3 and α_4 or to both β_3 and β_4 , as the case may be. This would force either δ to form a bigon with α_k or η to form a bigon with β_k , since otherwise \mathcal{D} would contain the bigon region between α_0 and δ or the bigon region between β_0 and η , and a Maslov index-1 rectangular domain in a nice Heegaard diagram can only be tiled by rectangular regions. But the nice Heegaard diagrams we produced in Lemma 3.4 do not allow any α_k to intersect δ or any β_k to intersect η for $k \geq 3$. Therefore, such a rectangular domain cannot exist. On the other hand, if \mathcal{D} is a bigon and $p_{\mathbf{y}^1} \neq p_{\mathbf{y}^2}$, then we have either $p_{\mathbf{y}^1} = (2, j)$ or $p_{\mathbf{y}^1} = (i, 1)$ while $p_{\mathbf{y}^2} = (1, j)$ or $p_{\mathbf{y}^2} = (i, 2)$, respectively. (Think of the bigons formed between α_0 and δ , and between β_0 and η , as models.) It follows, in particular, that if $p_{\mathbf{y}^1} = (1, 2)$, then $p_{\mathbf{y}^2} = (1, 2)$. \square

Consequently, the submodule of $\widehat{CF}(\Sigma, \beta, \alpha)$ generated by \vec{y} with $p_{\mathbf{y}} = (1, 2)$ is a subcomplex. We will denote this subcomplex by $\widehat{CF}_\circ(\Sigma, \beta, \alpha)$ for future reference. Next we investigate the holomorphic domains contributing to the differential of a generator \vec{y}^1 of $\widehat{CF}(\Sigma, \beta', \alpha')$ corresponding to a generator \vec{y}^1 of $\widehat{CF}(\Sigma, \beta, \alpha)$.

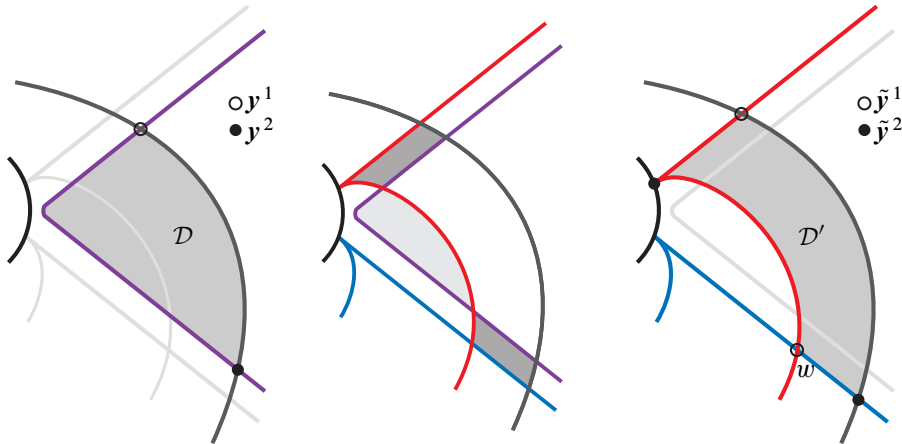

Figure 12: Constructing domains in $(\Sigma, \beta', \alpha', z')$ from domains in $(\Sigma, \beta, \alpha, z)$. Starting with a domain in the multipointed Heegaard diagram $(\Sigma, \beta, \alpha, z)$ as on the left, add the darker shaded rectangular regions and subtract the lighter shaded bigon region in the center to get the domain in the multipointed Heegaard diagram $(\Sigma, \beta', \alpha', z')$ shown on the right.

Lemma 3.6 *Given a generator y^1 of $\widehat{CF}(\Sigma, \beta, \alpha)$ and a generator \vec{y} of $\widehat{CF}(\Sigma, \beta', \alpha')$, if $p_{y^1} \neq (1, 2)$, then there exists a Maslov index-1 holomorphic domain $D' \in \widehat{\pi}_2(\vec{y}^1, \vec{y})$ only if $\vec{y} = \vec{y}^2$ for some generator \vec{y}^2 of $\widehat{CF}(\Sigma, \beta, \alpha)$ with $p_{y^2} \neq (1, 2)$.*

Proof To see this, write $\vec{y}^1 = \{y'^1_1, y'^1_2, \dots, y'^1_N\}$ and $\vec{y} = \{y'_1, y'_2, \dots, y'_N\}$, and recall that either $y'^1_1 = x'_1$, $y'^1_1 = w$ or $y'^1_2 = x'_2$. If $y'^1_1 = x'_1$ or $y'^1_2 = x'_2$, then $y'_1 = x'_1$ or $y'_2 = x'_2$, respectively, since there are no nontrivial Maslov index-1 holomorphic domains with a corner at x'_1 or x'_2 . If $y'^1_1 = w$, then either $y'_1 = x'_1$, $y'_1 = w$ or $y'_2 = x'_2$ since a Maslov index-1 holomorphic domain with a corner at w has to have a corner at x'_1 or x'_2 . The latter is due to the fact that the multipointed Heegaard diagram $(\Sigma, \beta', \alpha', z')$ is nice, so all Maslov index-1 holomorphic domains are empty embedded bigons or rectangles, and that starting at w and moving along α'_1 or β'_2 there is nowhere else to turn a corner other than at x'_1 or at x'_2 . As a result, $\vec{y} = \vec{y}^2$ for some generator \vec{y}^2 of $\widehat{CF}(\Sigma, \beta, \alpha)$ with $p_{y^2} \neq (1, 2)$. \square

Lemma 3.7 *Given generators \vec{y}^1 and \vec{y}^2 of $\widehat{CF}(\Sigma, \beta, \alpha)$, if $p_{y^1} \neq (1, 2)$ and $p_{y^2} \neq (1, 2)$, then there is a canonical one-to-one correspondence between Maslov index-1 holomorphic domains in $\widehat{\pi}_2(\vec{y}^1, \vec{y}^2)$ and Maslov index-1 holomorphic domains in $\widehat{\pi}_2(\vec{y}^1, \vec{y}^2)$.*

Proof Keep in mind that the Heegaard diagrams $(\Sigma, \beta, \alpha, z)$ and $(\Sigma, \beta', \alpha', z')$ are both nice. In particular, a Maslov index-1 holomorphic domain has a unique holomorphic representative up to translation. If \tilde{y}^1 and \tilde{y}^2 are generators of $\widehat{CF}(\Sigma, \beta, \alpha)$ with $p_{y^1} \neq (1, 2)$ and $p_{y^2} \neq (1, 2)$, then a Maslov index-1 holomorphic domain $\mathcal{D} \in \widehat{\pi}_2(\tilde{y}^1, \tilde{y}^2)$ gives rise to a canonical Maslov index-1 holomorphic domain $\mathcal{D}' \in \widehat{\pi}_2(\tilde{y}^1, \tilde{y}^2)$, and vice versa. If a domain \mathcal{D} has neither α_0 nor β_0 on its boundary, then $\mathcal{D}' = \mathcal{D}$. Otherwise, to construct \mathcal{D}' from \mathcal{D} we add rectangular regions between α_0 and α'_1 , α_0 and α'_2 , β_0 and β'_1 or β_0 and β'_2 , while removing the bigon regions between α_0 and β'_2 or α'_1 and β_0 as needed (see Figure 12). The former operation is reversible if \mathcal{D}' has α'_1 or α'_2 , and β'_1 or β'_2 on its boundary. \square

Lemma 3.8 *If \tilde{y}^1 and \tilde{y}^2 are generators of $\widehat{CF}(\Sigma, \beta, \alpha)$ with $p_{y^1} \neq (1, 2)$ and $p_{y^2} \neq (1, 2)$ and $\mathcal{D} \in \widehat{\pi}_2(\tilde{y}^1, \tilde{y}^2)$ is a Maslov index-1 holomorphic domain, then the corresponding Maslov index-1 holomorphic domain $\mathcal{D}' \in \widehat{\pi}_2(\tilde{y}^1, \tilde{y}^2)$ has $J_+(\mathcal{D}') = J_+(\mathcal{D})$.*

Proof To see this, first note the following:

- If $p_y = (1, 1)$ or $p_y = (2, 2)$, then $|\tilde{y}| = |y| + 1$.
- If $p_y = (2, 1)$, then $|\tilde{y}| = |y|$.

As before, if \mathcal{D} has neither α_0 nor β_0 on its boundary, then $\mathcal{D}' = \mathcal{D}$, and hence $J_+(\mathcal{D}') = J_+(\mathcal{D})$. Now suppose that \mathcal{D} has either α_0 or β_0 on its boundary.

- If \mathcal{D} is a rectangle, then $p_{y^1} = p_{y^2}$ (by Lemma 3.5) and \mathcal{D}' is a rectangle. Hence, $|\tilde{y}^1| - |\tilde{y}^2| = |y^1| - |y^2|$ and $J_+(\mathcal{D}') = J_+(\mathcal{D})$.
- If \mathcal{D} is a bigon, then $p_{y^1} = (2, 1)$ (otherwise $p_{y^2} = (1, 2)$) and either $p_{y^2} = (1, 1)$ or $p_{y^2} = (2, 2)$ (by Lemma 3.5), and \mathcal{D}' is a rectangle. Hence, $|\tilde{y}^1| - |\tilde{y}^2| = |y^1| - |y^2| - 1$ and

$$J_+(\mathcal{D}') = 2 \cdot 1 - 1 + |\tilde{y}^1| - |\tilde{y}^2| = 2 \cdot \frac{1}{2} - 1 + |y^1| - |y^2| = J_+(\mathcal{D}),$$

by (2-6). \square

By Lemma 3.5, the module $\widehat{CF}_o(\Sigma, \beta, \alpha)$ generated by \tilde{y} with $p_y = (1, 2)$ is a subcomplex of $\widehat{CF}(\Sigma, \beta, \alpha)$. Therefore, we may construct the quotient complex $\widehat{CF}(\Sigma, \beta, \alpha) / \widehat{CF}_o(\Sigma, \beta, \alpha)$. Note that, since $p_{x_\xi} = (1, 1)$, it is sent under the quotient map $q: \widehat{CF}(\Sigma, \beta, \alpha) \rightarrow \widehat{CF}(\Sigma, \beta, \alpha) / \widehat{CF}_o(\Sigma, \beta, \alpha)$ to a nonzero class. The filtered extension of the quotient, $(\widehat{CF}(\Sigma, \beta, \alpha) / \widehat{CF}_o(\Sigma, \beta, \alpha)) \otimes_{\mathbb{F}} \mathbb{F}[t, t^{-1}]$, is canonically

isomorphic as a filtered chain complex to the quotient $\widehat{\mathcal{CF}}(S, \phi, \mathbf{a})/\widehat{\mathcal{CF}}_{\circ}(S, \phi, \mathbf{a})$. The quotient map

$$\widehat{\mathcal{CF}}(S, \phi, \mathbf{a}) \rightarrow \widehat{\mathcal{CF}}(S, \phi, \mathbf{a})/\widehat{\mathcal{CF}}_{\circ}(S, \phi, \mathbf{a})$$

is a filtered chain map and it induces a morphism of associated spectral sequences. Therefore, if we define $o_q(S, \phi, \mathbf{a})$ to be the spectral order as determined by the class $q(x_{\xi})$ and the spectral sequence associated to the filtered quotient chain complex $(\widehat{\mathcal{CF}}(\Sigma, \beta, \alpha)/\widehat{\mathcal{CF}}_{\circ}(\Sigma, \beta, \alpha)) \otimes_{\mathbb{F}} \mathbb{F}[t, t^{-1}]$, then $o(S, \phi, \mathbf{a}) \geq o_q(S, \phi, \mathbf{a})$. Meanwhile, by Lemmas 3.6 and 3.7, there exists an injective map from $\widehat{\mathcal{CF}}(\Sigma, \beta, \alpha)/\widehat{\mathcal{CF}}_{\circ}(\Sigma, \beta, \alpha)$ to $\widehat{\mathcal{CF}}(\Sigma, \beta', \alpha')$ sending \vec{x}_{ξ} to \vec{x}'_{ξ} , and hence an injective map of filtered chain complexes from $(\widehat{\mathcal{CF}}(\Sigma, \beta, \alpha)/\widehat{\mathcal{CF}}_{\circ}(\Sigma, \beta, \alpha)) \otimes_{\mathbb{F}} \mathbb{F}[t, t^{-1}]$ into $\widehat{\mathcal{CF}}(S, \phi, \mathbf{a}')$ by Lemma 3.8, which induces a morphism of associated spectral sequences. As a result, $o_q(S, \phi, \mathbf{a}) \geq o(S, \phi, \mathbf{a}')$, finishing the proof of Proposition 3.3. \square

Definition 3.9 It follows from Proposition 3.3 that, for the purpose of defining the contact invariant \mathbf{o} , it suffices to work with arc collections that are bases with multiple parallel copies of some arcs added, since one can always pass to such an arc collection, which we will refer to as a *multibasis*, via triangle elimination without increasing the value of o . In other words, we may define $\mathbf{o}(M, \xi)$ to be the minimum of $o(S, \phi, \mathbf{a})$ over all choices of open book decompositions (S, ϕ) of M supporting ξ and multibases \mathbf{a} .

4 Properties of \mathbf{o}

The first bullet point of Theorem 1.1, that is, \mathbf{o} vanishes for overtwisted contact structures, was proved at the end of Section 2. This section proves the remaining properties of the contact invariant \mathbf{o} summarized in Theorems 1.1, 1.2 and 1.3.

To start, we establish a few basic properties of o . To do so, we work in a slightly more general context, where we consider arc collections that may not contain a basis. Let (S, ϕ) be an open book decomposition. Given an arc collection \mathbf{a} on S that does not necessarily contain a basis, we can extend it to an arc collection $\tilde{\mathbf{a}}$ that contains a basis. Then we fix a generic almost complex structure J_{HF} for the multipointed Heegaard diagram $(\Sigma, \tilde{\beta}, \tilde{\alpha}, \tilde{z})$ associated to the arc collection $\tilde{\mathbf{a}}$. We may regard $\widehat{\mathcal{CF}}(\Sigma, \beta, \alpha)$ as a submodule of $\widehat{\mathcal{CF}}(\Sigma, \tilde{\beta}, \tilde{\alpha})$ by identifying the generators of $\widehat{\mathcal{CF}}(\Sigma, \beta, \alpha)$ with the generators obtained from these via adding on the distinguished points lying in $S \times \{\frac{1}{2}\}$ for each of the arcs in $\tilde{\mathbf{a}} \setminus \mathbf{a}$. Due to the placement of the basepoints, there can be no pseudo-holomorphic curves with negative punctures at the chords resulting from these points.

Therefore, the differentials on $\widehat{CF}(\Sigma, \beta, \alpha)$ and on the submodule of $\widehat{CF}(\Sigma, \tilde{\beta}, \tilde{\alpha})$ that it is identified with coincide. As a result, we may consider $\widehat{CF}(\Sigma, \beta, \alpha)$ as a subcomplex of $\widehat{CF}(\Sigma, \tilde{\beta}, \tilde{\alpha})$. With the preceding understood, the first basic property of o is that it is nonincreasing under enlargement of arc collections.

Lemma 4.1 *Suppose that $\mathbf{a}_1 \subset \mathbf{a}_2$ are two collections of pairwise disjoint properly embedded arcs on S . Then there exists a generic almost complex structure J_{HF} on $\Sigma \times [0, 1] \times \mathbb{R}$ and an inclusion of chain complexes*

$$I: \widehat{CF}(\Sigma, \beta_1, \alpha_1) \rightarrow \widehat{CF}(\Sigma, \beta_2, \alpha_2), \quad \mathcal{I}: \widehat{CF}(S, \phi, \mathbf{a}_1) \rightarrow \widehat{CF}(S, \phi, \mathbf{a}_2)$$

such that the contact generator is mapped to the contact generator by the first inclusion while the latter inclusion induces a morphism of spectral sequences from $E^*(S, \phi, \mathbf{a}_1; J_{HF})$ to $E^*(S, \phi, \mathbf{a}_2; J_{HF})$; hence, $o(S, \phi, \mathbf{a}_1; J_{HF}) \geq o(S, \phi, \mathbf{a}_2; J_{HF})$.

Proof It suffices to find a generic almost complex structure J_{HF} on $\Sigma \times [0, 1] \times \mathbb{R}$ such that moduli spaces of J_{HF} -holomorphic curves associated to the Heegaard diagram $(\Sigma, \beta_2, \alpha_2)$ are cut out transversally, because this immediately implies transversality of moduli spaces of J_{HF} -holomorphic curves associated to the Heegaard diagram $(\Sigma, \beta_1, \alpha_1)$. Having fixed such a generic almost complex structure, the inclusion map I is defined on the set of generators of $\widehat{CF}(\Sigma, \beta_1, \alpha_1)$ by

$$I(\vec{y}) = \vec{y}',$$

where $\mathbf{y}' = \mathbf{y} \cup \{x_a\}_{a \in \mathbf{a}_2 \setminus \mathbf{a}_1}$ and x_a is the unique intersection point of a and b for an arc $a \in \mathbf{a}_2 \setminus \mathbf{a}_1$. It follows that $I(\vec{x}_\xi^1) = \vec{x}_\xi^2$. Meanwhile, the J_{HF} -holomorphic curves that define the differential acting on elements of the subgroup $I(\widehat{CF}(\Sigma, \beta_1, \alpha_1))$ are the same as the J_{HF} -holomorphic curves that define the differential on $\widehat{CF}(\Sigma, \beta_1, \alpha_1)$. Therefore, I is a chain map and the induced inclusion map \mathcal{I} is a filtered chain map. The latter induces a morphism of spectral sequences from $E^*(S, \phi, \mathbf{a}_1; J_{HF})$ to $E^*(S, \phi, \mathbf{a}_2; J_{HF})$; hence, $o(S, \phi, \mathbf{a}_1; J_{HF}) \geq o(S, \phi, \mathbf{a}_2; J_{HF})$. \square

The next lemma claims that o remains the same under suitable enlargement of the pages of an open book decomposition while keeping the arc collection untouched.

Lemma 4.2 *Let \mathbf{a} be a collection of pairwise disjoint properly embedded arcs on S and S' be a compact oriented surface with boundary obtained from S by attaching 1-handles away from a neighborhood of $\partial \mathbf{a}$. Let $\phi': S' \rightarrow S'$ be an orientation-preserving diffeomorphism whose restriction to \mathbf{a} agrees with ϕ . Then there are generic*

almost complex structures J_{HF} and J'_{HF} to define the differentials on $\widehat{CF}(\Sigma, \beta, \alpha)$ and $\widehat{CF}(\Sigma', \beta, \alpha)$, respectively, such that $(\widehat{CF}(S, \phi, \mathbf{a}), \widehat{\partial})$ and $(\widehat{CF}(S', \phi', \mathbf{a}), \widehat{\partial}')$ are isomorphic as filtered chain complexes. As a result, $o(S, \phi, \mathbf{a}; J_{HF}) = o(S', \phi', \mathbf{a}; J'_{HF})$.

Proof It follows from the description of the surface S' that \mathbf{a} can also be seen as a pairwise disjoint collection of properly embedded arcs on S' . Moreover, there is a canonical one-to-one correspondence between unordered tuples of intersection points in the Heegaard diagrams (Σ, β, α) and (Σ', β, α) . Also note that Σ' is obtained from Σ by connect-summing with tori along regions in the Heegaard diagram (Σ, β, α) with basepoints. Therefore, having fixed a generic almost complex structure J_{HF} on $\Sigma \times [0, 1] \times \mathbb{R}$, we can “extend” it to a generic almost complex structure J'_{HF} on $\Sigma' \times [0, 1] \times \mathbb{R}$ so that the holomorphic domains in the pointed Heegaard diagrams $(\Sigma, \beta, \alpha, z)$ and $(\Sigma', \beta, \alpha, z)$ agree, and the claim follows. \square

With the above understood, the proofs of Theorems 1.1, 1.2 and 1.3 require working with a more tractable version of o :

Definition 4.3 Let (M, ξ) be a closed contact 3–manifold. Fix an open book decomposition $\mathcal{B} = (S, \phi)$ of M supporting ξ . Then define

$$o(\mathcal{B}) := \min_{\mathbf{a}} \{o(S, \phi, \mathbf{a})\},$$

where the minimum is taken over all choices of multibasis \mathbf{a} on S . Indeed,

$$o(M, \xi) = \min_{\mathcal{B}} \{o(\mathcal{B})\}.$$

The quantity o yields an invariant of open book decompositions. We would like to understand its behavior under positive stabilization. Recall that a positive stabilization of an open book decomposition (S, ϕ) is an open book decomposition (S', ϕ') , where S' is obtained from S by attaching a 1–handle H and ϕ' differs from ϕ by a right-handed Dehn twist around a simple closed curve $c \subset S'$ that intersects the cocore of H in exactly one point; in other words, $\phi' = \phi \circ \tau_c$. As we will show next, o is nonincreasing under positive stabilization. To prove this, we need the flexibility to move from one arc collection to another without increasing the value of o . Recall that one can pass from one basis on S to another via a sequence of *arc slides*. Given a basis $\{a_1, a_2, \dots, a_G\}$ on S where a_1 and a_2 are adjacent — namely, there is an arc $\tau \subset \partial S$ with endpoints on a_1 and a_2 that intersects no other a_i — define $a_1 + a_2$ to be a properly embedded arc in S isotopic rel $\partial(a_1 \cup a_2) \simeq \partial\tau$ to $a_1 \cup \tau \cup a_2$ and

disjoint from all other a_i . Then passing from $\{a_1, a_2, \dots, a_G\}$ to $\{a_1 + a_2, a_2, \dots, a_G\}$ is called an arc slide. Somewhat similarly, given a multibasis on S , one can pass to a multibasis containing an arbitrary arc basis on S via a sequence of *multiarc slides*. Given a multibasis \mathbf{a} containing a basis $\{a_1, a_2, \dots, a_G\}$ on S where a_1 and a_2 are adjacent and \mathbf{a} contains m parallel copies of the arc a_1 , a multiarc slide removes all parallel copies of the arc a_1 and adds $m + 1$ parallel copies of the arc $a_1 + a_2$ as well as m additional parallel copies of the arc a_2 . This modification is equivalent to adding a copy of the arc $a_1 + a_2$ and then removing each parallel copy of the arc a_1 one by one via triangle elimination, resulting in a new multibasis \mathbf{a}' . Note that a multiarc slide with $m = 1$ is *not* an arc slide.

Lemma 4.4 *Let \mathbf{a} be a multibasis on S and \mathbf{a}' be obtained from \mathbf{a} by a multiarc slide. Then $o(S, \phi, \mathbf{a}') \leq o(S, \phi, \mathbf{a})$.*

Proof This follows readily from Lemma 4.1 and Proposition 3.3. □

Corollary 4.5 *Let $\mathcal{B} := (S, \phi)$ be an open book decomposition and $\mathcal{B}' := (S', \phi')$ be a positive stabilization of \mathcal{B} . Then $\circ(\mathcal{B}') \leq \circ(\mathcal{B})$.*

Proof Let \mathbf{a} be a multibasis such that $\circ(\mathcal{B}) = o(S, \phi, \mathbf{a})$. By a sequence of multiarc slides, pass to a multibasis \mathbf{a}' on S that is disjoint from c . Then $o(S, \phi, \mathbf{a}') = o(S, \phi, \mathbf{a})$ by Lemma 4.4, since $\circ(\mathcal{B}) = o(S, \phi, \mathbf{a})$, and $o(S', \phi', \mathbf{a}') = o(S, \phi, \mathbf{a}')$ by Lemma 4.2, since \mathbf{a}' is disjoint from c . As a result,

$$\circ(\mathcal{B}') \leq o(S', \phi', \mathbf{a}') = o(S, \phi, \mathbf{a}') = o(S, \phi, \mathbf{a}) = \circ(\mathcal{B}). \quad \square$$

Corollary 4.6 *Let $\mathcal{B} := (S, \phi)$ be an open book decomposition of M supporting ξ . Then we can apply a sequence of stabilizations to get to an open book decomposition \mathcal{B}' that realizes $\mathbf{o}(M, \xi)$.*

Proof This follows from Giroux correspondence together with Corollary 4.5. □

We move on to analyze the behavior of \mathbf{o} under Legendrian surgery.

Proposition 4.7 *Let (S, ϕ) be an open book decomposition and \mathbf{a} be any collection of pairwise disjoint properly embedded arcs on S that contains a basis. Suppose c is a homologically essential simple closed curve on S which meets each arc in $\phi(\mathbf{a})$ at most once. Then $o(S, \tau_c \circ \phi, \mathbf{a}) \geq o(S, \phi, \mathbf{a})$.*

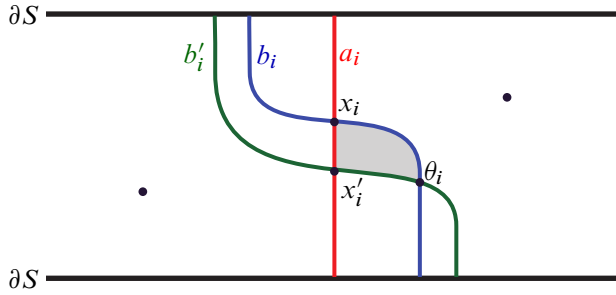

Figure 13: Part of the restriction of the multipointed Heegaard triple diagram $(\Sigma, \beta, \gamma, \alpha, z)$ to $S \times \{\frac{1}{2}\} \subset \Sigma$.

Proof To start, use (S, ϕ, \mathbf{a}) and the curve c to form a multipointed triple Heegaard diagram $(\Sigma, \beta, \gamma, \alpha, z)$, where $\gamma = \{\gamma_1, \dots, \gamma_N\}$ with $\gamma_i = b'_i \times \{\frac{1}{2}\} \cup \tau_c \circ \phi(b'_i) \times \{0\}$ such that b'_i is obtained from b_i by slightly pushing along ∂S in the direction of the boundary orientation as in Figure 13.

Notice that $(\Sigma, \beta, \alpha, z)$ is the multipointed Heegaard diagram associated to (S, ϕ, \mathbf{a}) and $(\Sigma, \gamma, \alpha, z)$ is the multipointed Heegaard diagram associated to $(S, \tau_c \circ \phi, \mathbf{a})$. Meanwhile, the multipointed Heegaard diagram (Σ, β, γ) describes a connected sum of some number of copies of the manifold $S^1 \times S^2$. Note also that the open book decomposition (S, τ_c) together with the collection of arcs $\{b_1, \dots, b_N\}$ specifies the Heegaard diagram (Σ, β, γ) , as in [23]. The chain complex $\widehat{CF}(\Sigma, \beta, \gamma)$ has trivial

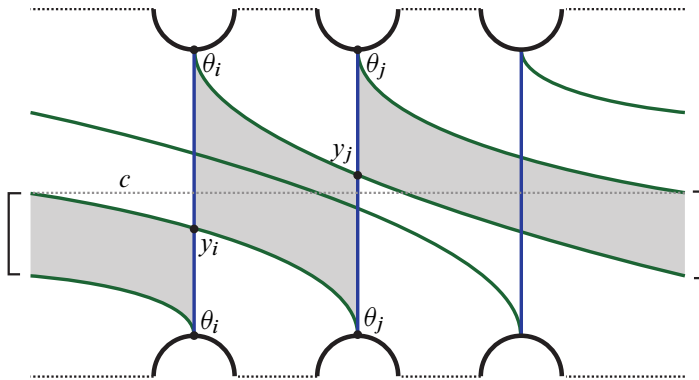

Figure 14: A local picture of the $-S \times \{0\} \subset \Sigma$ part of the Heegaard diagram (Σ, β, γ) near the surgery curve and all intersecting arcs. The shaded domains representing pseudoholomorphic curves with negative punctures at θ have the same J_+ value. The brackets indicate that the ends of the shaded region connect to one another.

differential and the generator $\vec{\theta}$ indicated in Figure 13 is the topmost generator. In fact, the J_+ -filtered differential on $\widehat{CF}(\Sigma, \beta, \gamma)$ is identically zero since all homology classes in $\widehat{\pi}_2(\vec{\theta}, \cdot)$ have the same J_+ value (see Figure 14).

The placement of the basepoints guarantees, once again, that the multipointed triple Heegaard diagram $(\Sigma, \beta, \gamma, \alpha, z)$ is admissible. Therefore, there is a chain map

$$(4-1) \quad \hat{f}_{\beta, \gamma, \alpha}: \widehat{CF}(\Sigma, \beta, \gamma) \otimes_{\mathbb{F}} \widehat{CF}(\Sigma, \gamma, \alpha) \rightarrow \widehat{CF}(\Sigma, \beta, \alpha)$$

induced by the cobordism described by the triple Heegaard diagram $(\Sigma, \beta, \gamma, \alpha)$. Since the differential on $\widehat{CF}(\Sigma, \beta, \gamma)$ is identically zero, $\mathbb{F} \cdot \vec{\theta} \otimes_{\mathbb{F}} \widehat{CF}(\Sigma, \gamma, \alpha, s_{\xi'})$ is a subcomplex of $\widehat{CF}(\Sigma, \beta, \gamma) \otimes_{\mathbb{F}} \widehat{CF}(\Sigma, \gamma, \alpha)$. Restricting (4-1) to this subcomplex, we obtain a chain map

$$\hat{f}_{\beta, \gamma, \alpha}(\vec{\theta} \otimes \cdot): \widehat{CF}(\Sigma, \gamma, \alpha, s_{\xi'}) \rightarrow \widehat{CF}(\Sigma, \beta, \alpha, s_{\xi}).$$

Therefore, having decomposed the above chain map as

$$\hat{f}_{\beta, \gamma, \alpha}(\vec{\theta} \otimes \cdot) = f^0 + f^1 + \dots + f^l + \dots,$$

where f^l counts embedded Fredholm index-0 pseudoholomorphic curves with $J_+ = 2l$, we have

$$(4-2) \quad \sum_{i+j=l} (f^i \circ \partial'_j - \partial_i \circ f^j) = 0$$

just as in Section 3. The identity (4-2) implies that there is a filtered chain map from $(\widehat{\mathcal{CF}}(S, \tau_c \circ \phi, \mathbf{a}), \hat{\partial}')$ to $(\widehat{\mathcal{CF}}(S, \phi, \mathbf{a}), \hat{\partial})$ and hence a morphism of spectral sequences from $E^*(S, \tau_c \circ \phi, \mathbf{a}; J'_{HF})$ to $E^*(S, \phi, \mathbf{a}; J_{HF})$. In addition, $\hat{f}_{\beta, \gamma, \alpha}(\vec{\theta} \otimes \vec{x}'_{\xi}) = \vec{x}_{\xi}$ since the shaded triangle in Figure 13 is the only holomorphic domain that contributes to this chain map due to the placement of the basepoints, and it is represented by a unique pseudoholomorphic curve by the Riemann mapping theorem. Hence, $o(S, \tau_c \circ \phi, \mathbf{a}; J'_{HF}) \geq o(S, \phi, \mathbf{a}; J_{HF})$, as desired. \square

Corollary 4.8 *Let $\mathcal{B} := (S, \phi)$ be an open book decomposition and suppose $\mathcal{B}' := (S, \phi')$ is obtained from \mathcal{B} by Legendrian surgery, ie $\phi' = \tau_{c_n} \circ \dots \circ \tau_{c_1} \circ \phi$. Then*

$$(4-3) \quad \circ(\mathcal{B}) \leq \circ(\mathcal{B}').$$

As a consequence, if $\mathcal{B} := (S, \phi)$ is an open book decomposition where ϕ can be written as a product of positive Dehn twists, then $\circ(\mathcal{B}) = \infty$.

Proof We will apply Proposition 4.7 one Dehn twist at a time, noting that, for each Dehn twist curve c_i , we can find a multibasis \mathbf{a} on S so that c_i intersects each arc in

the image of \mathbf{a} under the monodromy at most once. With the preceding understood, for each $i \in \{0, 1, \dots, n\}$ denote by \mathcal{B}_i the open book decomposition (S, ϕ_i) , where $\phi_0 = \phi$ and $\phi_i = \tau_{c_i} \circ \dots \circ \tau_{c_1} \circ \phi$ for $i \in \{1, \dots, n\}$. For each $i \in \{1, \dots, n\}$, fix a multibasis \mathbf{a}_i on S such that $\circ(\mathcal{B}_i) = o(S, \phi_i, \mathbf{a}_i)$. Performing a sequence of multiarc slides, pass to a multibasis \mathbf{a}'_i on S such that c_i intersects each arc in $\phi_{i-1}(\mathbf{a}'_i)$ at most once. It follows from Lemma 4.4 and Proposition 4.7 that

$$\circ(\mathcal{B}_{i-1}) \leq o(S, \phi_{i-1}, \mathbf{a}'_i) \leq o(S, \phi_i, \mathbf{a}'_i) = \circ(\mathcal{B}_i).$$

Concatenating these inequalities for $i \in \{1, \dots, n\}$ while noting that $\mathcal{B}_0 = \mathcal{B}$ and $\mathcal{B}_n = \mathcal{B}'$, we achieve the first claim of the corollary.

The last claim of the corollary follows immediately from (4-3) once we note that $\circ(S, \text{id}_S) = \infty$. The latter is because the J_+ -filtered differential in the corresponding Heegaard Floer chain complex is zero. □

With all the results needed in place, we are ready to prove Theorem 1.2, and the second bullet point of Theorem 1.1.

Proof of Theorem 1.2 First note that, if (M', ξ') is obtained from (M, ξ) by attaching a Weinstein 1–handle, then an open book decomposition supporting ξ' can be built from an open book decomposition (S, ϕ) supporting ξ by attaching a 1–handle to S and extending the monodromy ϕ as the identity over this handle. It is easy to see that the latter operation does not change the value of \circ , which then leads to the conclusion that $\circ(M', \xi') = \circ(M, \xi)$.

Next, for the case of a Weinstein 2–handle, let (M', ξ') be obtained from (M, ξ) by Legendrian surgery on a single curve c in (M, ξ) . Let c' be the Legendrian curve in (M', ξ') that is the core of the surgery solid torus, which has the property that contact +1–surgery on it yields (M, ξ) . The Legendrian c' lies on a page of an open book decomposition of M' supporting ξ' , which by Corollary 4.6 one can positively stabilize a number of times to get to an open book decomposition \mathcal{B}' which realizes $\circ(M', \xi')$; namely, $\circ(\mathcal{B}') = \circ(M', \xi')$. Now let \mathcal{B} be the open book decomposition of M supporting ξ that is obtained by contact +1–surgery on c' . By Corollary 4.8,

$$\circ(M, \xi) \leq \circ(\mathcal{B}) \leq \circ(\mathcal{B}') = \circ(M', \xi'). \quad \square$$

Corollary 4.9 *Let (M, ξ) be Stein-fillable. Then $\circ(M, \xi) = \infty$.*

Proof A Stein-fillable contact 3–manifold admits a supporting open book decomposition (S, ϕ) , where ϕ is a product of positive Dehn twists. To be more explicit, a Stein-fillable contact 3–manifold can be obtained via Legendrian surgery on some connected sum $\#_N S^1 \times S^2$ equipped with its standard contact structure ξ_{std} (see [18]). Therefore, by Theorem 1.2, it suffices to prove that $o(\#_N S^1 \times S^2, \xi_{\text{std}}) = \infty$. To see this, let \mathcal{B} be an open book decomposition of $\#_N S^1 \times S^2$ supporting ξ_{std} which realizes $o(\#_N S^1 \times S^2, \xi_{\text{std}})$; in other words, $o(\mathcal{B}) = o(\#_N S^1 \times S^2, \xi_{\text{std}})$. As $(\#_N S^1 \times S^2, \xi_{\text{std}})$ is supported by an open book with trivial monodromy, a common stabilization, \mathcal{B}' , of that and \mathcal{B} will have a monodromy which can be written as a product of positive Dehn twists and will also realize the minimal o . To see this, note that, by the second claim in Corollary 4.8, we have $o(\mathcal{B}') = \infty$. By Corollary 4.5, we also have $o(\mathcal{B}') \leq o(\mathcal{B}) = o(\#_N S^1 \times S^2, \xi_{\text{std}})$. Therefore, $o(\#_N S^1 \times S^2, \xi_{\text{std}}) = \infty$. \square

Next we prove the third bullet point of Theorem 1.1:

Theorem 4.10 *Given an open book decomposition $\mathcal{B} = (S, \phi)$ of M supporting ξ , and a basis \mathbf{a} on S , there exists a multibasis \mathbf{a}^m on S containing \mathbf{a} such that*

$$o(S, \phi, \mathbf{a}^m) = o(M, \xi).$$

Proof By Corollary 4.6, we can positively stabilize \mathcal{B} to pass to an open book decomposition $\mathcal{B}' = (S', \phi')$ with $o(\mathcal{B}') = o(M, \xi)$, where S' is built from S by adding 1–handles and $\phi' = \tau_{c_n} \circ \dots \circ \tau_{c_1} \circ \phi$. Extending ϕ to S' as the identity on all the 1–handles, we form the open book decomposition $\tilde{\mathcal{B}} = (S', \phi)$. Since ϕ' is obtained from ϕ by adding positive Dehn twists, $o(\tilde{\mathcal{B}}) \leq o(\mathcal{B}')$ by Corollary 4.8.

Now fix a multibasis \mathbf{a}' on S' such that

$$o(S', \phi', \mathbf{a}') = o(\mathcal{B}') = o(M, \xi).$$

Let a_1, \dots, a_n denote the cocores of the 1–handles added to S so as to build S' and perform a sequence of multiarc slides so as to pass to a multibasis \mathbf{a}'' that contains the arcs a_1, \dots, a_n and satisfies $o(S', \phi, \mathbf{a}'') = o(\tilde{\mathcal{B}})$. We also have $o(S', \phi', \mathbf{a}') = o(S', \phi', \mathbf{a}'')$ by Lemma 4.4. Let $\mathbf{a}^\circ = \mathbf{a}'' \cap S$ and note that \mathbf{a}° is a multibasis on S . Furthermore, ϕ acts trivially on all arcs in $\mathbf{a}'' \setminus \mathbf{a}^\circ$. Looking at the Heegaard diagram resulting from (S', ϕ, \mathbf{a}'') , the α – and β –curves corresponding to arcs in $S' \setminus S$ intersect each other exactly twice, forming two canceling bigons and thus contributing zero to $\widehat{\partial}_{HF}$. Furthermore, α_i and β_i intersect no other α –curves or β –curves. Thus,

$$\widehat{\mathcal{CF}}(S', \phi, \mathbf{a}'') \equiv \widehat{\mathcal{CF}}(S', \phi, \mathbf{a}^\circ) \otimes_{\mathbb{F}} (\mathbb{F}_{(0)} \oplus \mathbb{F}_{(1)})^{\otimes n},$$

where $\mathbb{F}_{(0)} \oplus \mathbb{F}_{(1)}$ is a graded module over \mathbb{F} with vanishing differential and n is the number of arcs in $\mathbf{a}'' \setminus \mathbf{a}^\circ$. In particular,

$$o(S', \phi, \mathbf{a}'') = o(S', \phi, \mathbf{a}^\circ).$$

By Lemma 4.2, we have $o(S, \phi, \mathbf{a}^\circ) = o(S', \phi, \mathbf{a}^\circ)$. Consequently,

$$o(S, \phi, \mathbf{a}^\circ) = o(S', \phi, \mathbf{a}^\circ) = o(S', \phi, \mathbf{a}'') \leq o(S', \phi', \mathbf{a}'') = o(S', \phi', \mathbf{a}') = o(M, \xi).$$

Since, by definition, $o(S, \phi, \mathbf{a}^\circ) \geq o(M, \xi)$, we have $o(S, \phi, \mathbf{a}^\circ) = o(M, \xi)$. Finally, given a basis \mathbf{a} on S , perform a sequence of multiarc slides to pass from \mathbf{a}° to a multibasis \mathbf{a}^m on S containing \mathbf{a} . Then, by Lemma 4.4,

$$o(S, \phi, \mathbf{a}^m) = o(S, \phi, \mathbf{a}^\circ) = o(M, \xi). \quad \square$$

Remark Given an open book decomposition (S, ϕ) and a multibasis \mathbf{a} on S , we can positively stabilize (S, ϕ) to pass to a new open book decomposition where \mathbf{a} becomes a basis. Then it follows from Corollary 4.6 and Theorem 4.10 that $o(M, \xi) = o(S, \phi, \mathbf{a})$ for some open book decomposition (S, ϕ) supporting the contact structure ξ and a basis \mathbf{a} on S .

Another application of the Legendrian surgery statement in Theorem 1.2 is Theorem 1.3, namely that the spectral order of a contact connected sum is the minimum of the orders of the summands:

Proof of Theorem 1.3 Let $\mathcal{B}_1 = (S_1, \phi_1)$ and $\mathcal{B}_2 = (S_2, \phi_2)$ be open book decompositions which realize $o(M_1, \xi_1)$ and $o(M_2, \xi_2)$, respectively. Fix multibases \mathbf{a}_1 and \mathbf{a}_2 on S_1 and S_2 , respectively, such that $o(\mathcal{B}_i) = o(S_i, \phi_i, \mathbf{a}_i)$ for $i = 1, 2$. Then both $\widehat{\mathcal{CF}}(S_1, \phi_1, \mathbf{a}_1)$ and $\widehat{\mathcal{CF}}(S_2, \phi_2, \mathbf{a}_2)$ can be seen as filtered subcomplexes of $\widehat{\mathcal{CF}}(S_\#, \phi_\#, \mathbf{a}_\#)$, where $\mathcal{B}_1 \# \mathcal{B}_2 = (S_\#, \phi_\#)$ is the boundary connected sum open book decomposition with $\phi_\# = \phi_2 \circ \phi_1$, where we extend each by the identity across the complementary subsurface and $\mathbf{a}_\# = \mathbf{a}_1 \sqcup \mathbf{a}_2$. Hence, by Lemmas 4.1 and 4.2,

$$o(M_1 \# M_2, \xi_1 \# \xi_2) \leq o(\mathcal{B}_1 \# \mathcal{B}_2) \leq o(\mathcal{B}_i) = o(M_i, \xi_i)$$

for both $i = 1$ and $i = 2$, and $o(M_1 \# M_2, \xi_1 \# \xi_2) \leq \min\{o(M_1, \xi_1), o(M_2, \xi_2)\}$.

For the reverse inequality, let $\mathcal{B} = (S, \phi)$ be a stabilization of $\mathcal{B}_1 \# \mathcal{B}_2$ realizing $o(M_1 \# M_2, \xi_1 \# \xi_2)$. Ignore the extra positive Dehn twists on \mathcal{B} which arise from its description as a positive stabilization of $\mathcal{B}_1 \# \mathcal{B}_2$. The resulting open book decomposition $\mathcal{B}' = (S, \phi')$ describes the 3-manifold $M_1 \# M_2 \# \#_k S^1 \times S^2$ for some k , the page S contains $S_1 \natural S_2$ as a subsurface due to \mathcal{B} being a positive stabilization of $\mathcal{B}_1 \# \mathcal{B}_2$,

and the monodromy ϕ' extends $\phi_{\#}$ as the identity to the rest of S . In particular, \mathcal{B} is obtained from \mathcal{B}' by Legendrian surgery along curves contained in a page of \mathcal{B} ; hence,

$$o(M_1 \# M_2, \xi_1 \# \xi_2) = o(\mathcal{B}) \geq o(\mathcal{B}'),$$

by Theorem 1.2.

Fix a multibasis \mathbf{a}' on S such that $o(\mathcal{B}') = o(S, \phi', \mathbf{a}')$. After a sequence of multiarc slides, we can pass to a multibasis $\tilde{\mathbf{a}}$ on S which contains $\mathbf{a}_1 \sqcup \mathbf{a}_2$. By Lemma 4.4 $o(\mathcal{B}') = o(S, \phi', \tilde{\mathbf{a}})$, and we have

$$\widehat{\mathcal{CF}}(S, \phi', \tilde{\mathbf{a}}) \cong \widehat{\mathcal{CF}}(S_1, \phi_1, \mathbf{a}_1) \otimes_{\mathbb{F}} \widehat{\mathcal{CF}}(S_2, \phi_2, \mathbf{a}_2) \otimes_{\mathbb{F}} (\mathbb{F}_{(0)} \oplus \mathbb{F}_{(1)})^{\otimes l}$$

as filtered chain complexes, where $\mathbb{F}_{(0)} \oplus \mathbb{F}_{(1)}$ is a graded module over \mathbb{F} with vanishing differential and l is some nonnegative integer. As a result, $o(\mathcal{B}') = o(S, \phi', \tilde{\mathbf{a}}) = \min\{o(S_1, \phi_1, \mathbf{a}_1), o(S_2, \phi_2, \mathbf{a}_2)\}$. On the other hand, since $o(S_1, \phi_1, \mathbf{a}_1) = o(\mathcal{B}_1) = o(M_1, \xi_1)$ and $o(S_2, \phi_2, \mathbf{a}_2) = o(\mathcal{B}_2) = o(M_2, \xi_2)$, by the above inequality we have

$$\min\{o(M_1, \xi_1), o(M_2, \xi_2)\} \leq o(M_1 \# M_2, \xi_1 \# \xi_2). \quad \square$$

Corollary 4.11 *For any surface S with boundary, the set of monodromies yielding open book decompositions supporting contact 3-manifolds (M, ξ) with $o(M, \xi) \geq k$ forms a monoid in the mapping class group $\text{Mod}(S, \partial S)$.*

We use $\mathcal{O}^k(S)$ to denote this monoid.

Proof By [1], for any two mapping classes ϕ_1 and ϕ_2 , there is a Stein cobordism starting at the disconnected contact manifold $(M_{\phi_1}, \xi_{\phi_1}) \sqcup (M_{\phi_2}, \xi_{\phi_2})$ and ending at $(M_{\phi_2 \circ \phi_1}, \xi_{\phi_2 \circ \phi_1})$. By Theorems 1.2 and 1.3, this implies that

$$\begin{aligned} o(M_{\phi_2 \circ \phi_1}, \xi_{\phi_2 \circ \phi_1}) &\geq o((M_{\phi_1}, \xi_{\phi_1}) \sqcup (M_{\phi_2}, \xi_{\phi_2})) \\ &= \min\{o(M_{\phi_1}, \xi_{\phi_1}), o(M_{\phi_2}, \xi_{\phi_2})\}. \end{aligned} \quad \square$$

5 Obstructing Stein-fillability

In this section, we use spectral order to obstruct Stein-fillability by demonstrating a family of contact 3-manifolds with nonzero Ozsváth–Szabó contact class but with zero spectral order. In Section 5.1, we give a warm-up example of this application on a contact manifold which had previously been shown to be nonfillable in [39; 9]. In Section 5.2, we generalize this method to a previously unstudied family of contact 3-manifolds thereby proving Theorem 1.4. Finally, in Section 5.3, we compare this

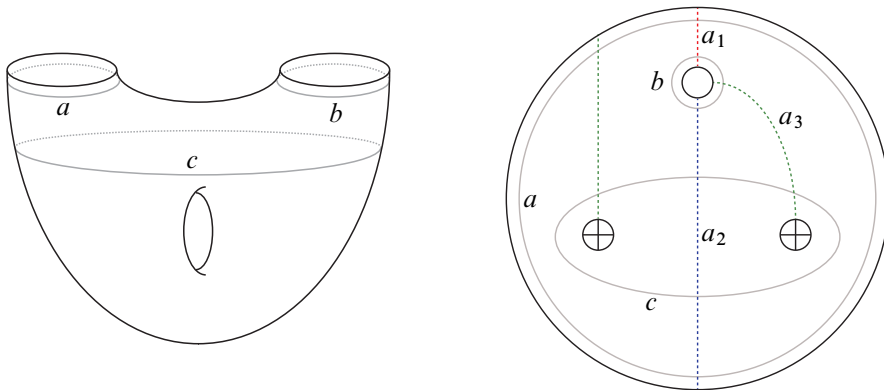

Figure 15: Left: the open book decomposition (S, ϕ) supporting the contact 3–manifold (Y, ξ) , where $\phi = \tau_a \tau_b \tau_c^{-1}$. Right: the basis of arcs $\mathbf{a} = \{a_1, a_2, a_3\}$ on S , where the two middle circles intersecting a_3 decorated with “plus” are identified.

method to other techniques in the literature for obstructing symplectic-fillability (in its various forms) in the context of these examples.

5.1 A warm-up

We start with a warm-up example (Y, ξ) , which is the base case of a family of contact 3–manifolds used by Conway in [9, Section 4]. The contact structure ξ is supported by the open book decomposition (S, ϕ) , where S is a compact oriented genus-1 surface with two boundary components and $\phi = \tau_a \tau_b \tau_c^{-1}$, the product of positive Dehn twists around the curves a and b and a negative Dehn twist around the curve c indicated in Figure 15, left. This is an open book decomposition for inadmissible transverse 2–surgery on the binding of an open book decomposition $(S_{1,1}, \text{id}_{S_{1,1}})$, where the page $S_{1,1}$ has genus 1 and one boundary component. The contact structure ξ has nonzero Ozsváth–Szabó contact class by [19, Corollary 4], as indicated by Conway.

Theorem 5.1 $o(Y, \xi) = 0$. Hence, (Y, ξ) is not Stein-fillable.

Proof To show that $o(Y, \xi) = 0$, we need to find a multibasis \mathbf{a} on S such that $o(S, \phi, \mathbf{a}) = 0$; more explicitly, we will find a generator \vec{y} of the resulting Heegaard Floer chain complex such that $\partial_0 \vec{y} = \vec{x}_\xi$. As we will show, it suffices to work with the basis of arcs $\{a_1, a_2, a_3\}$ depicted in Figure 15, right. The effect of the monodromy on this basis of arcs is shown in Figure 16. In what follows, a region without a basepoint will be denoted by R_i if it is numbered i in Figure 16.

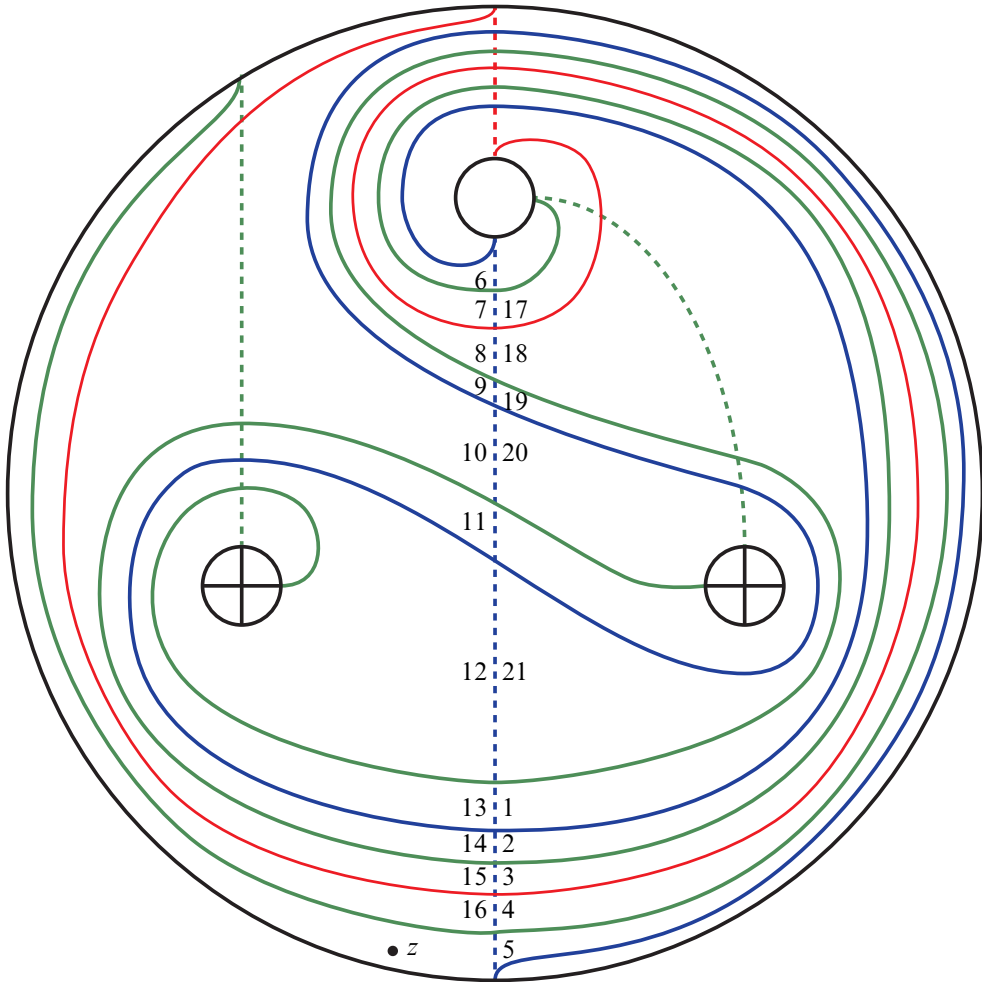

Figure 16: The effect of the monodromy applied to the basis of arcs. The resulting regions without basepoint are numbered $1, \dots, 21$.

We claim that the generator \vec{y} determined by the tuple of intersection points $\mathbf{y} = (x_1, y_2, y_3)$ satisfies $\partial_0 \vec{y} = \vec{x}_\xi$ (see Figure 17). To show this, we need to know in general what kind of Maslov index-1 domains have $J_+ = 0$.

Lemma 5.2 *Let D be a domain from \mathbf{y} to \mathbf{x} . If D has Maslov index 1 and $J_+(D) = 0$, then it is an immersed $2k$ -gon with only acute corners and no corners in its interior. Moreover, if D is any immersed $2k$ -gon with only acute corners and no corners in its interior, then it has Maslov index 1 and, furthermore, $J_+(D) = 0$ if and only if $|\mathbf{y}| - |\mathbf{x}| = 1 - k$.*

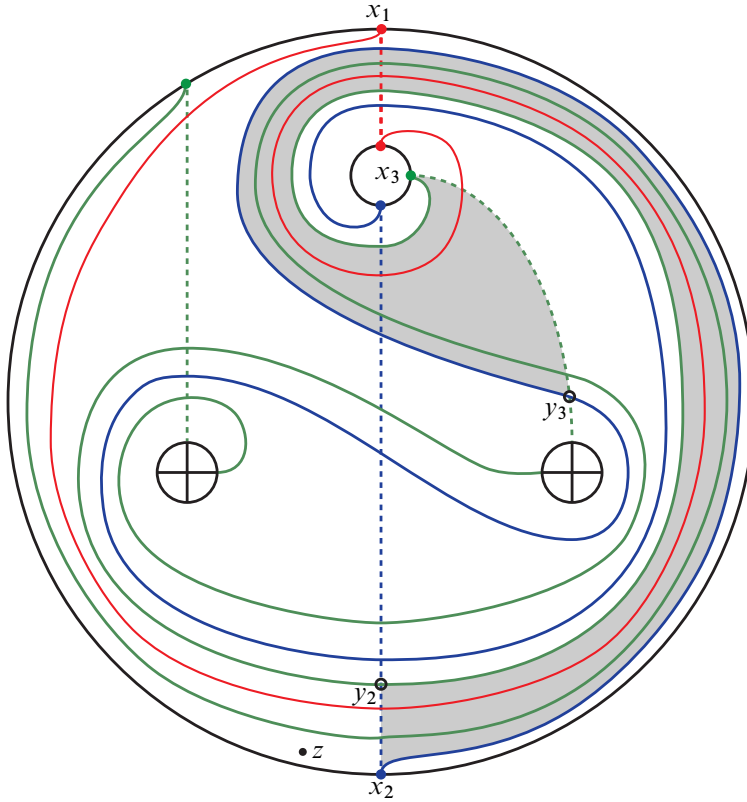

Figure 17: The domain \mathcal{D}_0 (shaded).

Proof Let \mathcal{D} be a Maslov index-1 domain with $J_+ = 0$, and suppose that \mathbf{y} and \mathbf{x} differ on k α -curves; hence, \mathcal{D} has $2k$ corners. By (2-6), we have

$$0 = J_+(\mathcal{D}) = 2(n_{\mathbf{y}}(\mathcal{D}) + n_{\mathbf{x}}(\mathcal{D})) - 1 + |\mathbf{y}| - |\mathbf{x}| \geq 2 \cdot \frac{2}{4}k - 1 + |\mathbf{y}| - |\mathbf{x}| = k - 1 + |\mathbf{y}| - |\mathbf{x}|.$$

In other words, $|\mathbf{x}| \geq |\mathbf{y}| + k - 1$. Conversely, let $\sigma_{\mathbf{y}}$ and $\sigma_{\mathbf{x}}$ denote the permutations associated to \mathbf{y} and \mathbf{x} , respectively, and denote by σ the composition $\sigma_{\mathbf{x}}\sigma_{\mathbf{y}}^{-1}$. Since \mathbf{y} and \mathbf{x} differ on k α -curves, the smallest number of transpositions that σ can be written as a composition of is bounded from above by $k - 1$, which is realized if and only if σ is a k -cycle. Next write σ as the composition of disjoint cycles. Note that composing a permutation with a transposition either merges two disjoint cycles, which reduces the number of disjoint cycles by 1, or breaks up a cycle into two disjoint cycles, which increases the number of disjoint cycles by 1. Therefore, $\sigma_{\mathbf{x}} = \sigma\sigma_{\mathbf{y}}$ can have at most $k - 1$ more disjoint cycles than $\sigma_{\mathbf{y}}$ has:

$$|\mathbf{x}| \leq |\mathbf{y}| + k - 1.$$

As a result, $|\mathbf{x}| = |\mathbf{y}| + k - 1$ and, in particular, σ is a k -cycle. We deduce from (2-6) that

$$n_{\mathbf{y}}(\mathcal{D}) + n_{\mathbf{x}}(\mathcal{D}) = \frac{1}{2}k,$$

implying that \mathcal{D} has point measure $\frac{1}{4}$ at each corner and that \mathcal{D} has connected boundary since σ is a k -cycle. Finally, by (2-3), we have $e(\mathcal{D}) = 1 - \frac{1}{2}k$, which is the Euler measure of a $2k$ -gon with only acute corners, none of which is in the interior of \mathcal{D} .

For the second claim, note that, if \mathcal{D} is a $2k$ -gon from \mathbf{y} to \mathbf{x} with each corner having point measure $\frac{1}{4}$, then it has Euler measure $1 - \frac{1}{2}k$ and Maslov index 1 by (2-3). Therefore,

$$J_+(\mathcal{D}) = k - 1 + 1 - k = 0. \quad \square$$

With regard to the second part of Lemma 5.2, note that, if $\mathbf{x} = \mathbf{x}_\xi$ and \mathcal{D} is a $2k$ -gon from \mathbf{y} to \mathbf{x}_ξ , then $|\mathbf{y}| - |\mathbf{x}_\xi| = 1 - k$.

A positive Maslov index-1 $J_+ = 0$ domain \mathcal{D}_0 from \mathbf{y} to \mathbf{x}_ξ is shaded in Figure 17. As a formal sum of regions without basepoints in the Heegaard diagram, it is given by

$$\mathcal{D}_0 = R_3 + R_4 + R_5 + R_7 + R_8 + R_9 + R_{17} + R_{18} + R_{19}.$$

This domain is an embedded rectangle. Therefore, it has a unique holomorphic representative for a generic split almost complex structure by the Riemann mapping theorem. In fact, this is the only domain that represents a positive class in $\hat{\pi}_2(\vec{\mathbf{y}}, \vec{\mathbf{x}}_\xi)$. This is because any other domain from \mathbf{y} to \mathbf{x}_ξ has to differ from \mathcal{D}_0 by a *periodic domain* representing a *periodic class* in $\hat{\pi}_2(\vec{\mathbf{y}}, \vec{\mathbf{y}})$. The latter is isomorphic to $H_2(Y; \mathbb{Z})$, which is a free abelian group of rank 2. A basis for $\hat{\pi}_2(\vec{\mathbf{y}}, \vec{\mathbf{y}})$ is given by the periodic domains

$$\begin{aligned} P_1 &= R_1 + R_4 + R_5 - R_6 - R_7 - R_{10} - R_{11} - R_{14} - R_{15} + R_{18} + R_{19} + R_{21}, \\ P_2 &= R_2 - R_5 + R_6 - R_9 + R_{11} + R_{13} + 2R_{14} + R_{15} + R_{16} - R_{17} - R_{18} - 2R_{19} \\ &\quad - R_{20} - R_{21}. \end{aligned}$$

If $\mathcal{D}_0 + aP_1 + bP_2$ is a positive domain from \mathbf{y} to \mathbf{x}_ξ , then, in particular,

$$0 + a \geq 0, \quad 0 + b \geq 0, \quad 0 - a \geq 0, \quad 0 - b \geq 0$$

via the multiplicities of the regions R_1, R_2, R_{10} and R_{20} , respectively. As a result, $a = 0 = b$.

Next we argue that there are no other positive Maslov index-1 $J_+ = 0$ domains from \mathbf{y} . To see this, let \mathcal{D} be such a domain from \mathbf{y} to some \mathbf{v} defining a generator of the

Heegaard Floer chain complex, and move along the boundary of \mathcal{D} in its boundary orientation. Note firstly that, due to the placement of the basepoint, \mathcal{D} cannot have a corner at x_1 . Therefore, \mathcal{D} must be an immersed rectangle as none of the regions are bigons. As a result, $\mathbf{v} = (x_1, v_2, v_3)$ for some $v_i \in \alpha_i \cap \beta_i$ for $i = 2, 3$. Note further that the region R_{12} adjacent to y_3 is an immersed 8-gon. Being a positive Maslov index-1 $J_+ = 0$ domain with four corners, \mathcal{D} must have Euler measure $e(\mathcal{D}) = 0$. As Euler measure is additive under unions and \mathcal{D} is a positive domain, \mathcal{D} cannot contain the region R_{12} , which has Euler measure -1 . Hence, \mathcal{D} contains only the region R_{19} among the four regions adjacent to y_3 . Now $v_3 \neq x_3$, since otherwise $\mathcal{D} = \mathcal{D}_0$. Moreover, as \mathcal{D} does not contain the region R_0 with basepoint, it contains R_{19} with multiplicity 1 and does not contain the region R_{18} . This forces \mathcal{D} to be contained in the formal sum

$$R_5 + R_9 + R_{19},$$

as \mathcal{D} cannot contain the 6-gon regions R_1 and R_{10} , which have Euler measure $-\frac{1}{2}$. But then, \mathcal{D} cannot have a corner at y_2 , which is a contradiction.

Consequently, we have $\partial_0 \vec{\mathbf{y}} = \vec{\mathbf{x}}_\xi$ which implies that $o(Y, \xi) = o(S, \phi, \mathbf{a}) = 0$ as the spectral order is defined to be the minimum over all choices of open book decompositions (S, ϕ) supporting ξ and multibases \mathbf{a} on S . Consequently, by the second bullet point of Theorem 1.1, (Y, ξ) is not Stein-fillable. \square

Remark In fact, $\widehat{\partial}_{HF} \vec{\mathbf{y}} = \partial_0 \vec{\mathbf{y}} + \partial_1 \vec{\mathbf{y}} = \vec{\mathbf{x}}_\xi + \vec{\mathbf{w}}$ where $\vec{\mathbf{w}}$ is determined by the tuple of intersection points $\mathbf{w} = (x_1, w_2, w_3)$ (see Figure 18). The domain \mathcal{D}_1 from \mathbf{y} to \mathbf{w} shown in Figure 18 is an embedded genus-1 surface with one boundary component and $J_+(\mathcal{D}_1) = 2$ given by the formal sum

$$\mathcal{D}_1 = R_{11} + R_{12} + R_{13} + R_{14}.$$

Arguing similarly to before, we see that, if $\mathcal{D}_1 + aP_1 + bP_2$ is another positive domain from \mathbf{y} to \mathbf{w} , then, in particular,

$$0 + a \geq 0, \quad 0 + b \geq 0, \quad 0 - a \geq 0, \quad 0 - b \geq 0$$

via the multiplicities of the regions R_1, R_2, R_7 and R_9 , respectively. As a result, $a = 0 = b$. Furthermore, a slightly more general version of the argument above proves that there are no other positive Maslov index-1 domains from \mathbf{y} . In particular, the domain \mathcal{D}_1 has a unique (up to a signed count) holomorphic representative, since otherwise $\widehat{\partial}_{HF} \vec{\mathbf{y}} = \vec{\mathbf{x}}_\xi$, contradicting the nonvanishing of the Ozsváth–Szabó contact class.

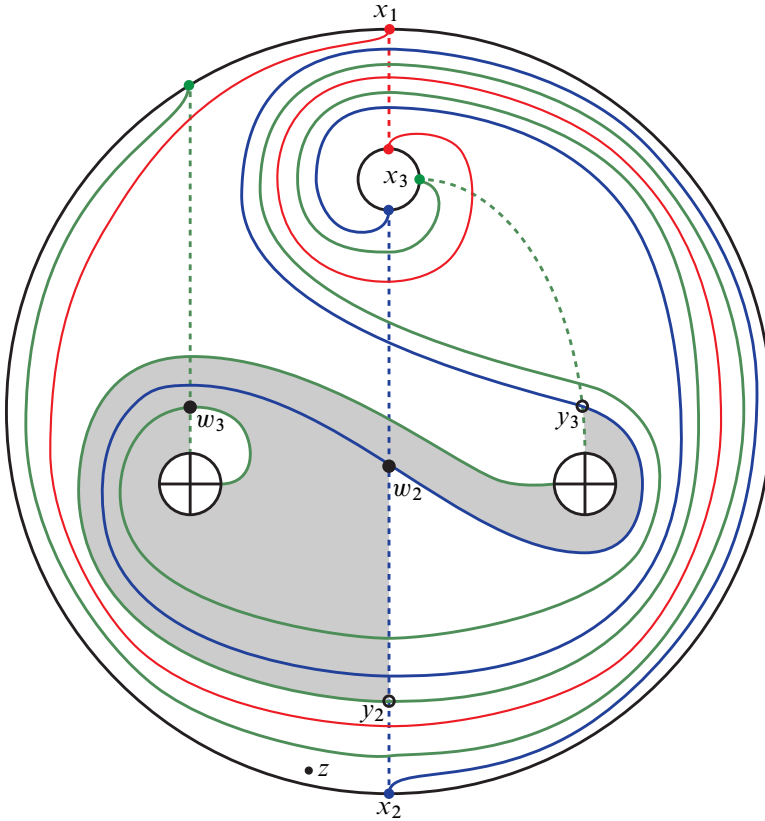

Figure 18: The domain \mathcal{D}_1 (shaded). Keep in mind that the middle two circles are identified.

5.2 A family of examples

In this section, we investigate an infinite family of contact 3-manifolds $\{(Y_p, \xi_p)\}_{p \in \mathbb{Z}_{>0}}$. For each $p \in \mathbb{Z}_{\geq 0}$, the contact structure ξ_p is supported by the open book decomposition $(S_{2,2}, \phi_p)$, where $S_{2,2}$ is a compact oriented genus-2 surface with two boundary components and $\phi_p = \tau_a^3 \tau_b \tau_c^{-1} \tau_d^p$, the product of positive Dehn twists around the curves a and b , a negative Dehn twist around the curve c , and p positive Dehn twists around the curve d indicated in Figure 19, left. The manifolds Y_p are obtained by $-1/p$ -surgery on a horizontal curve in the circle bundle, Y_0 , with Euler number $+4$ over a closed oriented surface of genus 2. Therefore, these manifolds are toroidal and have nontrivial JSJ decompositions. In the case $p = 0$, Honda [20] gave a complete a classification of tight contact structures (see also Giroux [16]). The contact structure ξ_0 is the unique virtually overtwisted contact structure on Y_0 , and its nonfillability was established by Lisca and

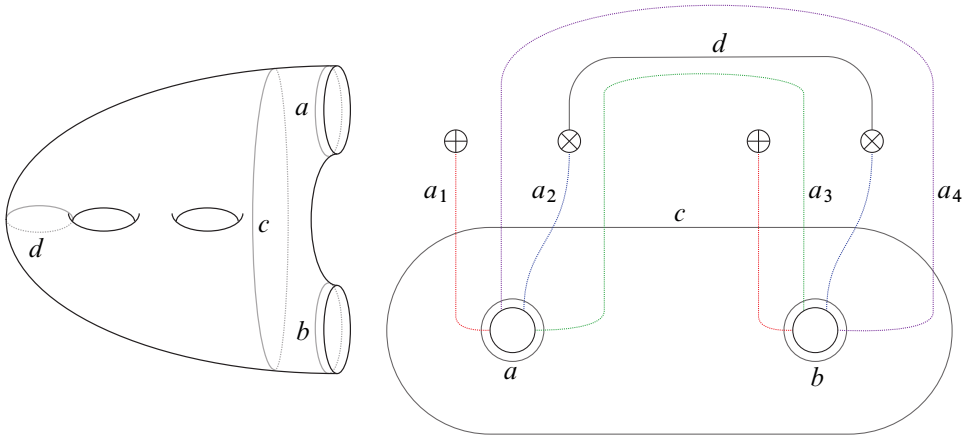

Figure 19: Left: a page of the open book decomposition $(S_{2,2}, \phi_p)$ supporting the contact structure ξ_p , where $\phi_p = \tau_a^3 \tau_b \tau_c^{-1} \tau_d^p$. Right: the same surface, where the two circles decorated with “plus” are identified, as are the two circles decorated with “cross”.

Stipsicz [39] (see Section 5.3 below for a detailed discussion). The contact structure ξ_p for $p \geq 0$ can be constructed by first applying inadmissible transverse surgery (with framing $+4$) on the genus-2 Borromean knot K in $L(p, p-1) \# \#_3 S^1 \times S^2$, which is the binding of an open book decomposition that supports the unique tight contact structure on this manifold, then resolving the resulting rational open book decomposition into an integral one following Conway [9]. As with the genus-1 example in Section 5.1, the contact structures ξ_p have nonzero Ozsváth–Szabó contact class by [19, Corollary 4].

Theorem 5.3 $\sigma(Y_p, \xi_p) = 0$ for $p \geq 1$. Hence, (Y_p, ξ_p) is not Stein-fillable for $p \geq 1$.

To put the above theorem in context, our examples fit somewhere in between the circle bundle example of Lisca and Stipsicz and positive-integer surgeries on the $(2, 5)$ -torus knot. In the former case, the monodromy is trivial away from the pair of pants at the boundary. In the latter, the monodromy has four positive Dehn twists: those that fit along the standard length-four chain. These two examples — Lisca and Stipsicz’s and positive-integer surgeries on the $(2, 5)$ -torus knot — behave differently as one increases the surgery coefficient. Increasing the surgery coefficient on K by 1 corresponds to adding a single positive Dehn twist along the curve a to the monodromy. The Lisca–Stipsicz examples remain nonfillable for all higher-integer surgeries, whereas $+9$ -surgery on the $(2, 5)$ -torus knot yields a tight contact structure on a lens space; hence, it is Stein-fillable. All higher-integer surgeries on the $(2, 5)$ -torus knot then

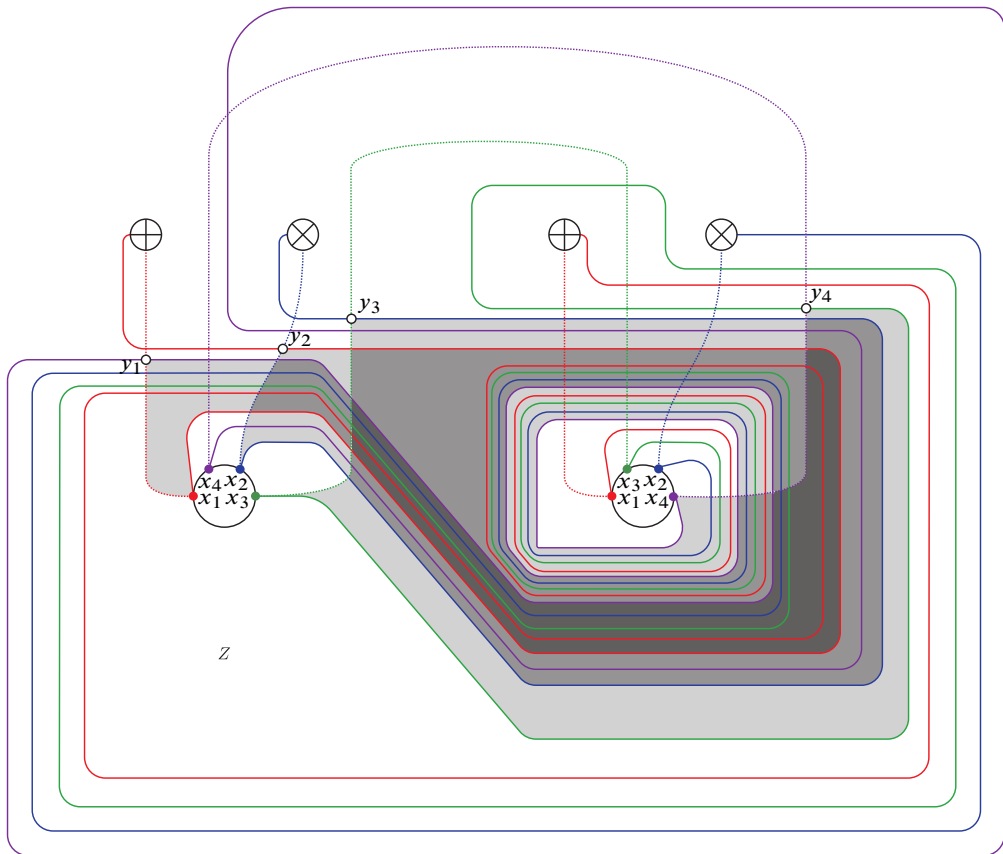

Figure 20: The effect of the monodromy applied to the arcs a_1, a_2, a_3 and a_4 (dotted) on $S_{2,2}$. Also shown is the domain \mathcal{D} (shaded) with darker shading indicating 1 higher multiplicity.

remain Stein-fillable. Our initial calculations for $+4$ -surgery on the $(2, 5)$ -torus knot suggest that in this case $\mathfrak{o} = \infty$. For the examples ξ_p when $p > 0$, we expect \mathfrak{o} to remain finite (though possibly nonzero) for all integer surgeries higher than $+4$, and therefore that all resulting contact structures remain non-Stein-fillable. It would be interesting to know whether these contact structures are weakly or strongly fillable.

Proof of Theorem 5.3 A basis of arcs on $S_{2,2}$ consists of five pairwise disjoint properly embedded arcs. In what follows, we work with a collection of four pairwise disjoint properly embedded arcs $\mathbf{a} = \{a_1, a_2, a_3, a_4\}$ to show that $\mathfrak{o}(Y_p, \xi_p) = 0$. Adding extra arcs would not change the result in light of Lemma 4.1. These arcs are shown in Figure 19, right, while their respective images under the monodromy are shown

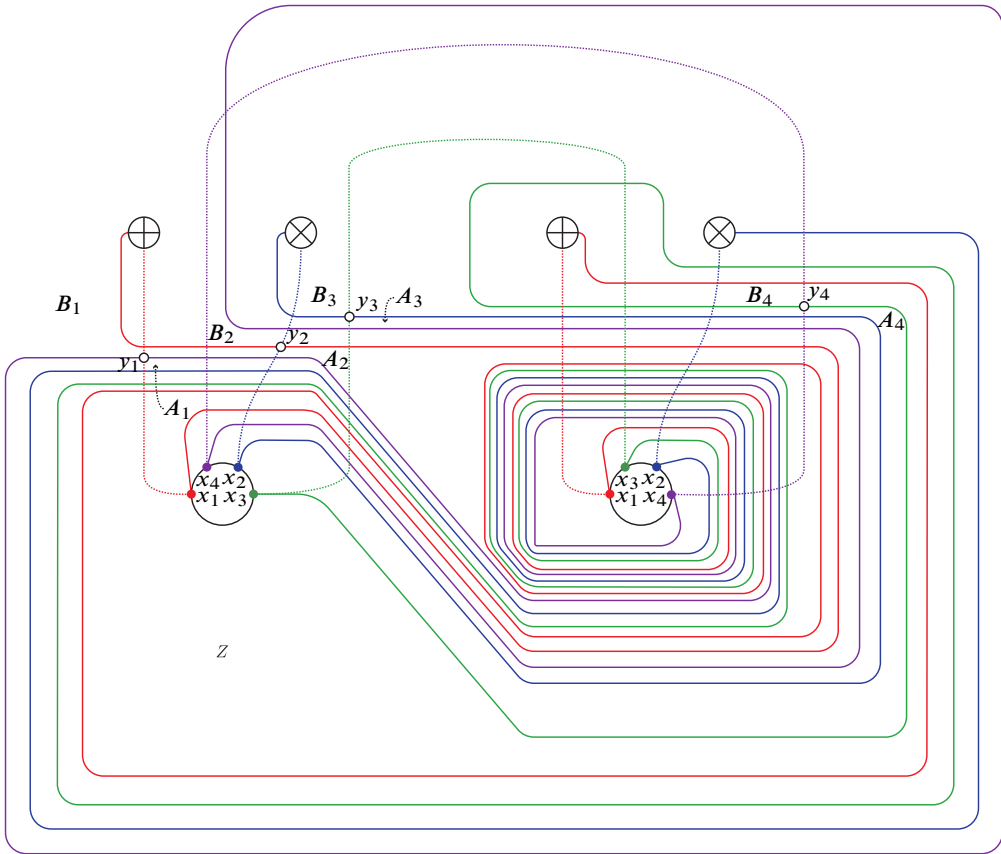

Figure 21: The regions A_i and B_i for $i = 1, \dots, 4$ and the region Z with basepoint.

in Figure 20. Also shown in the latter figure is a positive Maslov index-1, $J_+ = 0$ domain \mathcal{D} from $\mathbf{y} = (y_1, y_2, y_3, y_4)$ to $\mathbf{x}_{\xi_p} = (x_1, x_2, x_3, x_4)$, which is an immersed octagon and therefore has a unique holomorphic representative for a generic split almost complex structure. Our goal is to show that \mathcal{D} is the only positive Maslov index-1, $J_+ = 0$ domain from \mathbf{y} .

Suppose that \mathcal{D}' is a positive Maslov index-1, $J_+ = 0$ domain from \mathbf{y} to some $\mathbf{w} = (w_1, w_2, w_3, w_4)$. We will show that $\mathcal{D}' = \mathcal{D}$. To begin, for each y_i , label the region with corner at y_i having nonzero coefficient in \mathcal{D} as A_i , and let B_i denote the region whose intersection with A_i in a neighborhood of y_i consists only of the point y_i (see Figure 21). We label one of the regions with basepoint as Z and denote the multiplicity of a region R in \mathcal{D}' by $|R|$. Since $J_+(\mathcal{D}') = 0$, \mathcal{D}' has only acute corners and a connected boundary by Lemma 5.2; hence, if y_i is a corner of \mathcal{D}' , then $\{|A_i|, |B_i|\} = \{0, 1\}$. Note also

that, as B_3 is an annulus with eight acute corners, it has Euler measure -2 . Therefore, $|B_3| = 0$, since $e(\mathcal{D}') \geq -1$ and Euler measure is additive.

Next suppose that y_4 is a corner of \mathcal{D}' and that $|A_4| = 1$. Following β_3 along the boundary of \mathcal{D}' starting from y_4 , we deduce that, in order to avoid Z , we must have $w_3 = x_3$, which forces y_3 to be a corner of \mathcal{D}' and $|A_3| = 1$. Similarly, for $i = 2$ and $i = 3$, if y_i is a corner of \mathcal{D}' and $|A_i| = 1$, we may follow along β_{i-1} to conclude that, so as to avoid Z , we must have $w_{i-1} = x_{i-1}$; hence, y_{i-1} is a corner of \mathcal{D}' and $|A_{i-1}| = 1$. Finally, if y_1 is a corner of \mathcal{D}' and $|A_1| = 1$, following β_4 along the boundary of \mathcal{D}' , we conclude that, so as to avoid B_3 , we must have $w_4 \in \beta_4 \cap \alpha_4$; therefore, y_4 should be a corner of \mathcal{D}' and $|A_4| = 1$. In conclusion, if $|A_i| \neq 0$ for any $i = 1, \dots, 4$, then $|A_i| \neq 0$ and $w_i = x_i$ for all $i = 1, \dots, 4$. Checking the coefficients this forces in the remaining regions, we conclude that the only such domain is \mathcal{D} itself.

It remains to consider the case that $|A_i| = 0$ for all $i = 1, \dots, 4$. As noted above, $|B_3| = 0$, from which we conclude that y_3 is not a corner of \mathcal{D}' ; hence, $\partial\mathcal{D}'$ contains no segment of α_3 or β_2 . Supposing then that y_2 is a corner of \mathcal{D}' with $|B_2| = 1$, we may follow α_2 along the boundary of \mathcal{D}' to see that, in order to avoid B_3 , w_2 should be the corner of B_2 along β_4 , forcing y_1 to be a corner of \mathcal{D}' . Similarly, if y_1 is a corner of \mathcal{D}' with $|B_1| = 1$, then, following α_1 along the boundary of \mathcal{D}' , we deduce that there is a unique candidate for w_1 (ie a unique intersection point at which turning left leads to a y_i without creating a self-intersection in $\partial\mathcal{D}'$), which is along β_3 , forcing a corner at y_4 . Finally, if y_4 is a corner of \mathcal{D}' with $|B_4| = 1$, following α_4 along the boundary of \mathcal{D}' , we conclude that there are three possibilities for w_4 to avoid B_3 . Of these, one is along β_2 , which would force y_3 to be a corner of \mathcal{D}' , and another is along β_3 , which would lead us back to y_4 along a homotopically nontrivial path, a contradiction as \mathcal{D}' can have only one boundary component. We conclude that w_4 should be the corner of B_4 along β_1 ; hence, y_2 is a corner of \mathcal{D}' . It follows that $\partial\mathcal{D}'$ has a single self-intersection, at the corner of B_1 in $\alpha_1 \cap \beta_1$, giving a contradiction. \square

5.3 Comparison with other known obstructions

Our goal in this section is to put our calculations of \mathfrak{o} for the contact 3-manifolds $\{(Y_p, \xi_p)\}_{p \in \mathbb{Z}_{>0}}$ into the broader context of obstructions to existence of weak, strong, exact and Stein fillings. Note that:

- (1) The contact structure ξ_p results from inadmissible transverse surgery with framing $+4$ on the genus-2 Borromean knot in $L(p, p-1) \# \#_3 S^1 \times S^2$ [9].

- (2) $\hat{c}(\xi_p) \neq 0$ by [19], since the surgery coefficient is $2g = 4$.
- (3) Capping the boundary along the curve a gives a weak symplectic 2–handle cobordism from Y_p to $L(p, p-1) \# \#_3 S^1 \times S^2$ [14].
- (4) $c_1(\xi_p)$ is torsion.
- (5) $d_3(\xi_p) = \frac{1}{4}(p-3)$ [39].

To see (4), note that $b_2(L(p, p-1) \# \#_3 S^1 \times S^2) = 3$ (or $= 4$ if $p = 0$) and that every homology class can be represented by embedded tori. As a result, the Bennequin–Eliashberg bound implies that $c_1(\xi_p)$ evaluates trivially on $H_2(L(p, p-1) \# \#_3 S^1 \times S^2)$; therefore, it must be torsion.

Coarsely, there are two methods to obstruct symplectic–fillability: via the vanishing of contact invariants from Floer homology and gauge theory — such as monopole Floer homology, Heegaard Floer homology and embedded contact homology — via structural algebraic properties of symplectic field theory (SFT) or contact homology, or by applying more context specific ad hoc methods. The vanishing of contact invariants in Floer homology obstructs strong–fillability and can be used to obstruct weak–fillability with a suitable coefficient system. For our examples, because $\hat{c}(\xi_p) \neq 0$, any obstruction to symplectic–fillability would fall into the ad hoc category. It is possible that weak/strong–fillability of these contact 3–manifolds could be obstructed by SFT, for example were the algebraic torsion to be nonzero [33]. It is also possible that one could obstruct strong–fillability using contact homology [51; 5; 25], again assuming one could both calculate it and show that there are no augmentations of the algebra. Neither of these methods seems particularly practical for these examples, but we don’t know.

In situations where contact invariants fail to obstruct symplectic–fillability or they are too difficult to calculate, other information can sometimes be utilized. Interesting families of contact 3–manifolds have been shown to be nonfillable by symplectic caps or other cobordisms. Prior to the introduction of contact invariants from Floer homology, all methods of obstructing fillability were ad hoc and relied on Gromov’s theory of pseudoholomorphic curves (eg [11; 12]), but they only apply to obstructing existence of strong fillings. The introduction of the contact invariant in Seiberg–Witten theory [29] provided a more universal tool to obstruct symplectic–fillability, but it was notoriously difficult to calculate. In [39], Lisca and Stipsicz studied a family of contact 3–manifolds $\{(Y_{g,n}, \xi_i)\}_{n \geq 2, g \geq 0, i=0,1}$ described by Honda [20] and Giroux [16] to show that they are not symplectically fillable. Rather than directly showing that the monopole contact

invariant is zero for this family, Lisca and Stipsicz first calculated the d_3 -invariants of these contact structures using descriptions of $(Y_{g,n}, \xi_i)$ as Legendrian surgeries on some Stein-fillable contact 3-manifolds. Building on earlier work of Lisca [36] and Mrowka, Ozsváth and Yu [43], they then conclude that in a given Spin^c structure, there is a unique homotopy class of 2-plane fields ξ containing a symplectically fillable contact structure. Finally, they use calculations of an η -invariant by Nicolaescu [44] to calculate the d_3 -invariant of ξ and see that it does not agree with the d_3 -invariants of ξ_i .

Often filling obstructions follow by finding a symplectic cobordism to either the empty set or some target contact 3-manifold (M, ξ) whose symplectic fillings are classified—such as certain contact structures on the lens spaces $L(p, q)$ (eg [42; 37])—or are obstructed entirely [14]. One then attempts to obstruct this cobordism from embedding in any filling of (M, ξ) . These methods build on the foundational examples and methods of Lisca in [36] (see [40; 28; 34]). There, strong-fillability is obstructed by finding a smooth 4-manifold cap which cannot be embedded into a diagonal lattice, noticing that the projection $c_{\text{red}}(\xi)$ of $c^+(\xi)$ onto the reduced Heegaard Floer homology is zero, so that all strong fillings must be negative-definite, and then invoking Donaldson's theorem to obstruct the existence of resulting closed smooth manifold. One can also invoke a relative version of this obstruction by Owens and Strle [47], using the Heegaard Floer d -invariants of M . This method also often obstructs existence of weak fillings as well, as at least some of the manifolds involved are rational homology spheres, where the two notions of weak and strong filling are equivalent. Similar obstructions are possible by finding symplectic caps which contain symplectic spheres of nonnegative square and then analyzing the resulting embedding into a ruled surface (eg [41]).

There are other methods of obstructing existence of even weak fillings in situations where property (2) and some version of properties (1) [10], (4) [28; 34] and (3) [40; 41] above hold. In [10], Conway, Etnyre and Tosun study a particular case. They investigate contact 3-manifolds Y_K obtained by inadmissible contact surgery on a transverse knot K in S^3 and obstruct existence of weak fillings in a very interesting range of surgery slopes determined by $\tau(K)$. Their obstruction is obtained by the relative adjunction inequality of Raoux [53] for knots in rational homology spheres, noting that any weak filling of Y_K embeds into a strong filling of S^3 in which K bounds a symplectic disk. There are generalizations of this method that work in the exact setting where Y_K is built by inadmissible surgery on a transverse knot K in a 3-manifold Y all of whose weak fillings are classified. We note that neither the Conway–Etnyre–Tosun nor Lisca–Stipsicz methods appear to be applicable to our family of contact

3–manifolds. The sphere of square $-p$ easily embeds into the diagonal lattice and there does not appear to be an obstruction to K bounding a symplectic disk of the appropriate type in a symplectic filling of $L(p, p - 1)$. We also note that, if our family of contact 3–manifolds were supported by planar open book decompositions, one could conceivably invoke Niederkrüger and Wendl [45; 57], as used by [27], to obstruct weak and strong fillings.

The obstructions particular to Stein-fillability generally require both that $c_{\text{red}}(\xi) = 0$ and that $d_3(\xi)$ be small (either less than 1 [28] or less than 0 [2]). To date, there is exactly one method to obstruct Stein-fillability of an exactly fillable contact 3–manifold [6]. This uses Eliashberg’s theorem on decomposing spheres [11] and requires the 3–manifold in question to be reducible. This method is entirely dependent on Ghiggini’s obstruction to existence of exact fillings of certain strongly fillable contact 3–manifolds. In [15], Ghiggini used properties of Stein fillings [38] and the behavior of Heegaard Floer homology under Spin^c conjugation to obstruct Stein-fillability on a number of Brieskorn spheres. Ghiggini’s method requires, among much else, that ξ be homotopic to its coorientation reversal, $\bar{\xi}$, which implies that $c_1(\xi) = 0$.

We note that the four simplifying properties (1)–(4) hold only because we have chosen a particularly simple family of contact 3–manifolds. One can tweak this family to construct examples where $\hat{c}(\xi) \neq 0$ but $\mathfrak{o}(\xi) = 0$ and where none of the properties (1)–(4) hold. In general, we expect that there are examples of contact 3–manifolds where both $c^+(\xi) \neq 0$ and $c_{\text{red}}(\xi) \neq 0$, but $\mathfrak{o}(\xi) < \infty$, and which have no reasonable cobordism to a contact 3–manifold whose fillings are classified or whose symplectic caps are constrained. For such contact 3–manifolds, the spectral order obstructs Stein-fillability but it is likely that no other current method could be applied to show this.

Finally, one major practical advantage of working with Heegaard Floer homology is its computability. Finding an upper bound for \mathfrak{o} is a direct calculation that can be done easily on any fixed open book decomposition. We carried out this task using a computer program that we wrote, building on a program of Sucharit Sarkar that analyzes Heegaard Floer chain complexes. The proofs given in Sections 5.1 and 5.2 were done by hand and verified by this computer program, which also gives us the capability to do calculations on much larger chain complexes. In conclusion, if \mathfrak{o} is finite, finding an upper bound for the explicit value is a relatively simple endeavor even if calculating the exact value is difficult. Hence, as a fillability obstruction when $\hat{c}(\xi) \neq 0$, \mathfrak{o} is both a robust contact invariant with its fundamental properties, and it is computable.

References

- [1] **K L Baker, J B Etnyre, J Van Horn-Morris**, *Cabling, contact structures and mapping class monoids*, J. Differential Geom. 90 (2012) 1–80 MR Zbl
- [2] **J A Baldwin**, *Heegaard Floer homology and genus one, one-boundary component open books*, J. Topol. 1 (2008) 963–992 MR Zbl
- [3] **J A Baldwin**, *Contact monoids and Stein cobordisms*, Math. Res. Lett. 19 (2012) 31–40 MR Zbl
- [4] **J Baldwin, D S Vela-Vick**, *A note on the knot Floer homology of fibered knots*, Algebr. Geom. Topol. 18 (2018) 3669–3690 MR Zbl
- [5] **E Bao, K Honda**, *Definition of cylindrical contact homology in dimension three*, J. Topol. 11 (2018) 1002–1053 MR Zbl
- [6] **J Bowden**, *Exactly fillable contact structures without Stein fillings*, Algebr. Geom. Topol. 12 (2012) 1803–1810 MR Zbl
- [7] **K Cieliebak, Y Eliashberg**, *From Stein to Weinstein and back: symplectic geometry of affine complex manifolds*, American Mathematical Society Colloquium Publications 59, Amer. Math. Soc., Providence, RI (2012) MR Zbl
- [8] **V Colin**, *Chirurgies d'indice un et isotopies de sphères dans les variétés de contact tendues*, C. R. Acad. Sci. Paris Sér. I Math. 324 (1997) 659–663 MR Zbl
- [9] **J Conway**, *Transverse surgery on knots in contact 3-manifolds*, Trans. Amer. Math. Soc. 372 (2019) 1671–1707 MR Zbl
- [10] **J Conway, J B Etnyre, B Tosun**, *Symplectic fillings, contact surgeries, and Lagrangian disks*, Int. Math. Res. Not. 2021 (2021) 6020–6050 MR Zbl
- [11] **Y Eliashberg**, *Filling by holomorphic discs and its applications*, from “Geometry of low-dimensional manifolds, II” (S K Donaldson, C B Thomas, editors), London Math. Soc. Lecture Note Ser. 151, Cambridge Univ. Press (1990) 45–67 MR Zbl
- [12] **Y Eliashberg**, *Unique holomorphically fillable contact structure on the 3-torus*, Int. Math. Res. Not. 1996 (1996) 77–82 MR Zbl
- [13] **J B Etnyre, J Van Horn-Morris**, *Monoids in the mapping class group*, from “Interactions between low-dimensional topology and mapping class groups” (R I Baykur, J Etnyre, U Hamenstädt, editors), Geom. Topol. Monogr. 19, Geom. Topol. Publ., Coventry (2015) 319–365 MR Zbl
- [14] **D T Gay**, *Four-dimensional symplectic cobordisms containing three-handles*, Geom. Topol. 10 (2006) 1749–1759 MR Zbl
- [15] **P Ghiggini**, *Strongly fillable contact 3-manifolds without Stein fillings*, Geom. Topol. 9 (2005) 1677–1687 MR Zbl
- [16] **E Giroux**, *Structures de contact en dimension trois et bifurcations des feuilletages de surfaces*, Invent. Math. 141 (2000) 615–689 MR Zbl

- [17] **E Giroux**, *Géométrie de contact: de la dimension trois vers les dimensions supérieures*, from “Proceedings of the International Congress of Mathematicians, II” (T Li, editor), Higher Ed., Beijing (2002) 405–414 MR Zbl
- [18] **R E Gompf**, *Handlebody construction of Stein surfaces*, *Ann. of Math.* 148 (1998) 619–693 MR Zbl
- [19] **M Hedden, O Plamenevskaya**, *Dehn surgery, rational open books and knot Floer homology*, *Algebr. Geom. Topol.* 13 (2013) 1815–1856 MR Zbl
- [20] **K Honda**, *On the classification of tight contact structures, II*, *J. Differential Geom.* 55 (2000) 83–143 MR Zbl
- [21] **K Honda, W H Kazez, G Matić**, *Right-veering diffeomorphisms of compact surfaces with boundary*, *Invent. Math.* 169 (2007) 427–449 MR Zbl
- [22] **K Honda, W H Kazez, G Matić**, *The contact invariant in sutured Floer homology*, *Invent. Math.* 176 (2009) 637–676 MR Zbl
- [23] **K Honda, W H Kazez, G Matić**, *On the contact class in Heegaard Floer homology*, *J. Differential Geom.* 83 (2009) 289–311 MR Zbl
- [24] **M Hutchings**, *The embedded contact homology index revisited*, from “New perspectives and challenges in symplectic field theory” (M Abreu, F Lalonde, L Polterovich, editors), CRM Proc. Lecture Notes 49, Amer. Math. Soc., Providence, RI (2009) 263–297 MR Zbl
- [25] **M Hutchings, J Nelson**, *Cylindrical contact homology for dynamically convex contact forms in three dimensions*, *J. Symplectic Geom.* 14 (2016) 983–1012 MR Zbl
- [26] **A Juhász, S Kang**, *Spectral order for contact manifolds with convex boundary*, *Algebr. Geom. Topol.* 18 (2018) 3315–3338 MR Zbl
- [27] **A Kaloti**, *Stein fillings of planar open books*, preprint (2013) arXiv 1311.0208
- [28] **A Kaloti, B Tosun**, *Hyperbolic rational homology spheres not admitting fillable contact structures*, *Math. Res. Lett.* 24 (2017) 1693–1705 MR Zbl
- [29] **P B Kronheimer, T S Mrowka**, *Monopoles and contact structures*, *Invent. Math.* 130 (1997) 209–255 MR Zbl
- [30] **Ç Kutluhan, G Matić, J V Horn-Morris, A Wand**, *Spectral order for sutured contact manifolds*, in preparation
- [31] **Ç Kutluhan, G Matić, J V Horn-Morris, A Wand**, *Spectral order is a non-trivial contact invariant*, in preparation
- [32] **Ç Kutluhan, G Matić, J Van Horn-Morris, A Wand**, *A Heegaard Floer analog of algebraic torsion*, from “Breadth in contemporary topology” (D T Gay, W Wu, editors), Proc. Sympos. Pure Math. 102, Amer. Math. Soc., Providence, RI (2019) 119–130 MR Zbl

- [33] **J Latschev, C Wendl**, *Algebraic torsion in contact manifolds*, *Geom. Funct. Anal.* 21 (2011) 1144–1195 MR Zbl With an appendix by Michael Hutchings
- [34] **Y Li, Y Liu**, *Hyperbolic 3–manifolds admitting no fillable contact structures*, *Proc. Amer. Math. Soc.* 147 (2019) 351–360 MR Zbl
- [35] **R Lipshitz**, *A cylindrical reformulation of Heegaard Floer homology*, *Geom. Topol.* 10 (2006) 955–1096 MR Zbl Correction in 18 (2014) 17–30
- [36] **P Lisca**, *Symplectic fillings and positive scalar curvature*, *Geom. Topol.* 2 (1998) 103–116 MR Zbl
- [37] **P Lisca**, *On lens spaces and their symplectic fillings*, *Math. Res. Lett.* 11 (2004) 13–22 MR Zbl
- [38] **P Lisca, G Matić**, *Tight contact structures and Seiberg–Witten invariants*, *Invent. Math.* 129 (1997) 509–525 MR Zbl
- [39] **P Lisca, A I Stipsicz**, *Tight, not semi-fillable contact circle bundles*, *Math. Ann.* 328 (2004) 285–298 MR Zbl
- [40] **P Lisca, A I Stipsicz**, *Ozsváth–Szabó invariants and tight contact 3–manifolds, III*, *J. Symplectic Geom.* 5 (2007) 357–384 MR Zbl
- [41] **S Lisi, C Wendl**, *Spine removal surgery and the geography of symplectic fillings*, *Michigan Math. J.* 70 (2021) 403–422 MR
- [42] **D McDuff**, *The structure of rational and ruled symplectic 4–manifolds*, *J. Amer. Math. Soc.* 3 (1990) 679–712 MR Zbl
- [43] **T Mrowka, P Ozsváth, B Yu**, *Seiberg–Witten monopoles on Seifert fibered spaces*, *Comm. Anal. Geom.* 5 (1997) 685–791 MR Zbl
- [44] **L I Nicolaescu**, *Eta invariants of Dirac operators on circle bundles over Riemann surfaces and virtual dimensions of finite energy Seiberg–Witten moduli spaces*, *Israel J. Math.* 114 (1999) 61–123 MR Zbl
- [45] **K Niederkrüger, C Wendl**, *Weak symplectic fillings and holomorphic curves*, *Ann. Sci. Éc. Norm. Supér.* 44 (2011) 801–853 MR Zbl
- [46] **Y-G Oh**, *Fredholm theory of holomorphic discs under the perturbation of boundary conditions*, *Math. Z.* 222 (1996) 505–520 MR Zbl
- [47] **B Owens, S Strle**, *Dehn surgeries and negative-definite four-manifolds*, *Selecta Math.* 18 (2012) 839–854 MR Zbl
- [48] **P Ozsváth, Z Szabó**, *Holomorphic disks and topological invariants for closed three-manifolds*, *Ann. of Math.* 159 (2004) 1027–1158 MR Zbl
- [49] **P Ozsváth, Z Szabó**, *Holomorphic disks and three-manifold invariants: properties and applications*, *Ann. of Math.* 159 (2004) 1159–1245 MR Zbl
- [50] **P Ozsváth, Z Szabó**, *Heegaard Floer homology and contact structures*, *Duke Math. J.* 129 (2005) 39–61 MR Zbl

- [51] **J Pardon**, *Contact homology and virtual fundamental cycles*, J. Amer. Math. Soc. 32 (2019) 825–919 MR Zbl
- [52] **O Plamenevskaya**, *A combinatorial description of the Heegaard Floer contact invariant*, Algebr. Geom. Topol. 7 (2007) 1201–1209 MR Zbl
- [53] **K Raoux**, *tau-invariants for knots in rational homology spheres*, PhD thesis, Brandeis University (2017) MR Available at <https://www.proquest.com/docview/1873863961>
- [54] **S Sarkar, J Wang**, *An algorithm for computing some Heegaard Floer homologies*, Ann. of Math. 171 (2010) 1213–1236 MR Zbl
- [55] **A Wand**, *Detecting tightness via open book decompositions*, from “Interactions between low-dimensional topology and mapping class groups” (R I Baykur, J Etnyre, U Hamenstädt, editors), Geom. Topol. Monogr. 19, Geom. Topol. Publ., Coventry (2015) 291–317 MR Zbl
- [56] **A Wand**, *Tightness is preserved by Legendrian surgery*, Ann. of Math. 182 (2015) 723–738 MR Zbl
- [57] **C Wendl**, *Strongly fillable contact manifolds and J -holomorphic foliations*, Duke Math. J. 151 (2010) 337–384 MR Zbl
- [58] **C Wendl**, *A hierarchy of local symplectic filling obstructions for contact 3-manifolds*, Duke Math. J. 162 (2013) 2197–2283 MR Zbl

*Department of Mathematics, University at Buffalo
Buffalo, NY, United States*

*Department of Mathematics, University of Georgia
Athens, GA, United States*

*Department of Mathematics, University of Arkansas
Fayetteville, AR, United States*

*School of Mathematics and Statistics, University of Glasgow
Glasgow, United Kingdom*

kutluhan@buffalo.edu, gordanam@uga.edu, jvhm@uark.edu,
andy.wand@glasgow.ac.uk

Proposed: András I Stipsicz
Seconded: Ciprian Manolescu, Peter Ozsváth

Received: 18 February 2020
Revised: 21 January 2022

GEOMETRY & TOPOLOGY

msp.org/gt

MANAGING EDITOR

András I. Stipsicz Alfréd Rényi Institute of Mathematics
stipsicz@renyi.hu

BOARD OF EDITORS

Dan Abramovich	Brown University dan_abramovich@brown.edu	Mark Gross	University of Cambridge mgross@dpms.cam.ac.uk
Ian Agol	University of California, Berkeley ianagol@math.berkeley.edu	Rob Kirby	University of California, Berkeley kirby@math.berkeley.edu
Mark Behrens	Massachusetts Institute of Technology mbehrens@math.mit.edu	Frances Kirwan	University of Oxford frances.kirwan@balliol.oxford.ac.uk
Mladen Bestvina	Imperial College, London bestvina@math.utah.edu	Bruce Kleiner	NYU, Courant Institute bkleiner@cims.nyu.edu
Martin R. Bridson	Imperial College, London m.bridson@ic.ac.uk	Urs Lang	ETH Zürich urs.lang@math.ethz.ch
Jim Bryan	University of British Columbia jbryan@math.ubc.ca	Marc Levine	Universität Duisburg-Essen marc.levine@uni-due.de
Dmitri Burago	Pennsylvania State University burago@math.psu.edu	John Lott	University of California, Berkeley lott@math.berkeley.edu
Ralph Cohen	Stanford University ralph@math.stanford.edu	Ciprian Manolescu	University of California, Los Angeles cm@math.ucla.edu
Tobias H. Colding	Massachusetts Institute of Technology colding@math.mit.edu	Haynes Miller	Massachusetts Institute of Technology hrm@math.mit.edu
Simon Donaldson	Imperial College, London s.donaldson@ic.ac.uk	Tom Mrowka	Massachusetts Institute of Technology mrowka@math.mit.edu
Yasha Eliashberg	Stanford University eliash-gt@math.stanford.edu	Walter Neumann	Columbia University neumann@math.columbia.edu
Benson Farb	University of Chicago farb@math.uchicago.edu	Jean-Pierre Otal	Université d'Orleans jean-pierre.otal@univ-orleans.fr
Steve Ferry	Rutgers University sferry@math.rutgers.edu	Peter Ozsváth	Columbia University oszvath@math.columbia.edu
Ron Fintushel	Michigan State University ronfint@math.msu.edu	Leonid Polterovich	Tel Aviv University polterov@post.tau.ac.il
David M. Fisher	Rice University davidfisher@rice.edu	Colin Rourke	University of Warwick gt@maths.warwick.ac.uk
Mike Freedman	Microsoft Research michaelf@microsoft.com	Stefan Schwede	Universität Bonn schwede@math.uni-bonn.de
David Gabai	Princeton University gabai@princeton.edu	Peter Teichner	University of California, Berkeley teichner@math.berkeley.edu
Stavros Garoufalidis	Southern U. of Sci. and Tech., China stavros@mpim-bonn.mpg.de	Richard P. Thomas	Imperial College, London richard.thomas@imperial.ac.uk
Cameron Gordon	University of Texas gordon@math.utexas.edu	Gang Tian	Massachusetts Institute of Technology tian@math.mit.edu
Lothar Götsche	Abdus Salam Int. Centre for Th. Physics gotsche@ictp.trieste.it	Ulrike Tillmann	Oxford University tillmann@maths.ox.ac.uk
Jesper Grodal	University of Copenhagen jg@math.ku.dk	Nathalie Wahl	University of Copenhagen wahl@math.ku.dk
Misha Gromov	IHÉS and NYU, Courant Institute gromov@ihes.fr	Anna Wienhard	Universität Heidelberg wienhard@mathi.uni-heidelberg.de

See inside back cover or msp.org/gt for submission instructions.

The subscription price for 2023 is US \$740/year for the electronic version, and \$1030/year (+ \$70, if shipping outside the US) for print and electronic. Subscriptions, requests for back issues and changes of subscriber address should be sent to MSP. Geometry & Topology is indexed by Mathematical Reviews, Zentralblatt MATH, Current Mathematical Publications and the Science Citation Index.

Geometry & Topology (ISSN 1465-3060 printed, 1364-0380 electronic) is published 9 times per year and continuously online, by Mathematical Sciences Publishers, c/o Department of Mathematics, University of California, 798 Evans Hall #3840, Berkeley, CA 94720-3840. Periodical rate postage paid at Oakland, CA 94615-9651, and additional mailing offices. POSTMASTER: send address changes to Mathematical Sciences Publishers, c/o Department of Mathematics, University of California, 798 Evans Hall #3840, Berkeley, CA 94720-3840.

GT peer review and production are managed by EditFLOW[®] from MSP.

PUBLISHED BY

 **mathematical sciences publishers**
nonprofit scientific publishing

<http://msp.org/>

© 2023 Mathematical Sciences Publishers

GEOMETRY & TOPOLOGY

Volume 27 Issue 6 (pages 2049–2496) 2023

- Duality between Lagrangian and Legendrian invariants 2049
TOBIAS EKHOLM and YANKI LEKILI
- Filtering the Heegaard Floer contact invariant 2181
ÇAĞATAY KUTLUHAN, GORDANA MATIĆ, JEREMY
VAN HORN-MORRIS and ANDY WAND
- Large-scale geometry of big mapping class groups 2237
KATHRYN MANN and KASRA RAFI
- On dense totipotent free subgroups in full groups 2297
ALESSANDRO CARDERI, DAMIEN GABORIAU and
FRANÇOIS LE MAÎTRE
- The infimum of the dual volume of convex cocompact
hyperbolic 3-manifolds 2319
FILIPPO MAZZOLI
- Discrete subgroups of small critical exponent 2347
BEIBEI LIU and SHI WANG
- Stable cubulations, bicombings, and barycenters 2383
MATTHEW G DURHAM, YAIR N MINSKY and
ALESSANDRO SISTO
- Smallest noncyclic quotients of braid and mapping class groups 2479
SUDIPTA KOLAY