



10<sup>th</sup> International Conference on Applied Energy (ICAE2018), 22-25 August 2018, Hong Kong, China

## Analysis of a combined trilateral cycle - organic Rankine cycle (TLC-ORC) system for waste heat recovery

Zhi Li <sup>a</sup>, Rui Huang <sup>a</sup>, Yiji Lu <sup>a,b,\*</sup>, Antony Paul Roskilly <sup>a,b</sup>, Xiaoli Yu <sup>a</sup>

<sup>a</sup>Department of Energy Engineering, Zhejiang University, 38 Zheda Road, Hangzhou, 310027, China

<sup>b</sup>Sir Joseph Swan Centre for Energy Research, Newcastle University, Newcastle upon Tyne, NE1 7RU, UK

### Abstract

A combined Trilateral Cycle-Organic Rankine Cycle (TLC-ORC) system for waste heat recovery is proposed in this paper in order to obtain a better matching performance between the heat source and working fluid. Working fluid selection including Cyclohexane, Toluene, Benzene and water for the high temperature cycle is analyzed based on thermodynamic model under different evaporating temperature of high temperature cycle and low temperature cycle. Results show that Toluene has the best performance among the studied four high temperature working fluid. The net power output, thermal efficiency and exergy efficiency increases with  $T_{evap,HT}$  or  $T_{evap,LT}$  increasing at any a high temperature working fluid. The maximum net power output 11.3 kW, thermal efficiency 24.2% and exergy efficiency 63.2% are achieved by Toluene at  $T_{evap,HT}=530$  K and  $T_{evap,LT}=373$  K at the same time. It is also found that evaporator 1 has the largest exergy destruction while condenser 1 has the smallest one among all the components. Meanwhile, the condenser 2 has the lowest exergy efficiency while condenser 1 has the highest one. These results show us the direction to optimize the system parameters to improve the total efficiency of the whole system.

© 2019 The Authors. Published by Elsevier Ltd.

This is an open access article under the CC BY-NC-ND license (<http://creativecommons.org/licenses/by-nc-nd/4.0/>)

Peer-review under responsibility of the scientific committee of ICAE2018 – The 10th International Conference on Applied Energy.

*Keywords:* Organic Rankine cycle; Trilateral cycle; Waste heat recovery; Exergy analysis

### 1. Introduction

In recent years, ORC has been widely investigated for waste heat recovery in many situations such as engines, ships and other industrial applications [1-3]. In terms of the ORC technology, there are many prototypes such as basic ORC systems and dual-loop or cascaded systems. However, in conventional ORC systems heat transfer

*E-mail address:* [yiji.lu@zju.edu.cn](mailto:yiji.lu@zju.edu.cn); [luyiji0620@gmail.com](mailto:luyiji0620@gmail.com) (Y. Lu)

process in the evaporators has a poor performance of temperature matching between the heat source and working fluid, causing relatively high irreversibility and poor thermodynamic performance in the end [4]. However, TLC has a smaller exergy loss in the evaporator because the working fluid directly flows into expander after heated in the evaporator without evaporating process. Thus, the temperature difference between the working fluid and heat source can be quite smaller compared to conventional cycles. In recent years, TLC has been increasingly studied. Johann Fischer studied the performances of optimized TLC and basic optimized ORC for waste heat recovery. Results show that the exergy efficiency can be 14% ~29% larger than that of ORC under various inlet temperature of heat source and inlet temperature of the coolant [5]. M. Yari et al. compared TLC, ORC and Kalina cycle from the view of exergoeconomic performance recovering low grade heat source. The conclusion is that TLC has better power output performance than that of ORC and Kalina cycle, but its device cost is determined by the expander isentropic efficiency to a great extent. It is also illustrated that adopting n-butane as the working fluid can lead to the lowest invest cost for TLC [6]. Ramon Ferreiro Garcia et al. conducted similar research and revealed that within a range of relatively low operating temperatures, TLC can obtain high thermal efficiency of 44.9% compared to 33.9% of Carnot cycle under the same high and low temperature heat reservoir [7].

Overall, TLC has better performance of temperature profile matching in the evaporator compared to conventional power cycles. Considering this superiority, an original dual-loop ORC system is proposed with TLC being the high temperature cycle in this research.

## 2. System description

Figure 1 shows the T-s diagram of high and low temperature cycle. Figure 2 shows the layout of proposed combined TLC-ORC waste heat recovery system. TLC system composes of a heat exchanger, a condenser, a pump and an expander. Specially, the expander used in TLC can sustain two-phase flow. At state 1 the high temperature working fluid (HTWF) is saturated liquid with temperature  $T_1$  and pressure  $p_1$ . Later the pressure of liquid is compressed to  $p_2$  by the pump 1 at state 2. Then HTWF enters the heat exchanger where it is heated to the evaporating temperature at pressure  $p_2$ , which is the state 3. Thereafter, HTWF directly flows into the expander, where HTWF expands as the wet vapor and gradually attains the state 4 with the pressure  $p_1$  and temperature  $T_1$ . At this state the mass fraction of vapor is set as  $x_4$ . Effective work is delivered during the expanding process of HTWF. Finally, the wet vapor is fully condensed at state 1.

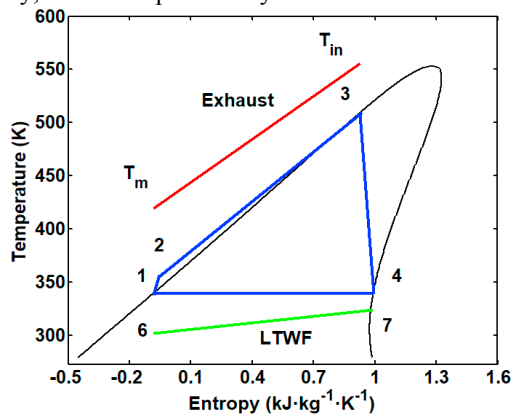

(a) T-s diagram of high temperature cycle;

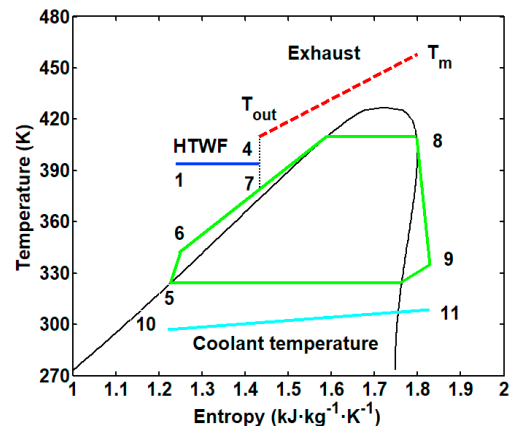

(b) T-s diagram of low temperature cycle

Figure 1 T-s diagrams for high and low temperature cycle.

For low temperature cycle, low temperature working fluid (LTWF) is compressed from state 5 to 6, then it absorbs waste heat of HTWF in the condenser 1 to improve the total utilization rate of waste heat. LTWF continues to absorb heat from exhaust in the evaporator 2, at the outlet of which LTWF is saturated vapor without overheating process. Then LTWF flows into expander 2 and mechanical work is produced by the expanding process. Finally, LTWF flows into condenser 2 and is condensed by the cooling water with the whole cycle finishing.

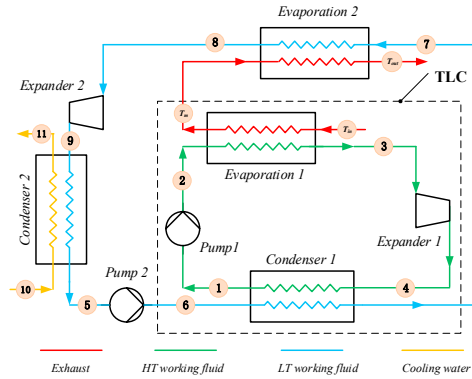

Figure 2. Schematic of combined TLC -ORC waste heat recovery system.

The TLC is adopted as high temperature cycle and in order to illuminate its detailed properties, three types of high temperature working fluid including cyclohexane, benzene, toluene and water are analysed in the system. Table 1 shows the main properties from REFPROP software. As for the low temperature cycle, R245fa is selected as working fluid because it is a common working fluid which is very suitable for the low-temperature heat source.

Table 1 Properties of the selected working fluid.

Working fluid	molecular weight (g/mol)	Normal boiling point (K)	Critical temperature (K)	Critical pressure (MPa)
Cyclohexane	84.16	353.9	553.6	4.075
Benzene	78.11	353.2	562.1	4.894
Toluene	92.14	383.8	591.8	4.126

### 3. Tables Methodology

Before establishing the thermodynamic model for the system, some imperative assumptions are listed in the following part:

- (1) Each thermodynamic process in the system works under a steady state.
- (2) Pressure drop and heat dissipation along all the pipes are ignored.
- (3) The kinetic and potential energy of working fluids are neglected.
- (4) Environmental temperature and pressure are respectively set as 298 K and 101 kPa.
- (5) The isentropic efficiency for two turbines is set as 0.85 while the isentropic efficiency for two pumps is assumed to be 0.65 [1].
- (6) The condensation temperature for low temperature cycle is assumed to be 308 K.
- (7) The minimum pinch point temperatures of liquid-liquid heat exchanger and liquid-gas heat exchanger are assumed to be 10 K and 30 K [2].

Performance evaluation and parametric analysis in this paper are based on the energy and exergy equations according to the first and the second thermodynamic laws. Before establishing the detailed model, the exergy at each state point should be defined [3].

$$E_i = m[(h_i - h_0) - T_0 \cdot (s_i - s_0)] \quad (1)$$

In the equation, 0 represents the base state and it is set to be the ambient in this work.

At first for the high temperature cycle:

- Process from state 1 to 2:

$$h_2 = h_1 + (h_{2s} - h_1) / \eta_{isen,p} \quad (2)$$

$$W_{p,1} = m_{wh} \cdot (h_2 - h_1) \quad (3)$$

$$I_{p,1} = (E_2 - E_1) + W_{p,1} \quad (4)$$

$$\eta_{ex,p,1} = (E_1 - E_5) / W_{p,1} \quad (5)$$

- Process from state 2 to 3:

$$m_{wh} \cdot (h_3 - h_2) = m_e \cdot (h_{e,in} - h_{e,m}) \quad (6)$$

$$I_{evap,1} = (E_{e,in} - E_{e,m}) - (E_3 - E_2) \quad (7)$$

$$\eta_{ex,evap,1} = (E_3 - E_2) / (E_{e,in} - E_{e,m}) \quad (8)$$

- Process from 3 to 4:

$$h_4 = h_3 - (h_3 - h_{4s}) \cdot \eta_{isen,expa} \quad (9)$$

$$W_{\text{expa},1} = m_{\text{wh}} \cdot (h_3 - h_4) \quad (10)$$

$$I_{\text{expa},1} = (E_3 - E_4) - W_{\text{expa},1} \quad (11)$$

$$\eta_{\text{ex,expa},1} = W_{\text{expa},1} / (E_3 - E_4) \quad (12)$$

• Process from 4 to 1:

$$m_{\text{wh}} \cdot (h_4 - h_1) = m_{\text{wl}} \cdot (h_7 - h_6) \quad (13)$$

$$I_{\text{cond},1} = (E_4 - E_1) - (E_7 - E_6) \quad (14)$$

$$\eta_{\text{ex,cond},1} = (E_4 - E_1) / (E_7 - E_6) \quad (15)$$

Then the mathematical equations for low temperature cycle are described as follows.

• Process from 5 to 6:

$$h_6 = h_5 + (h_{6s} - h_5) / \eta_{\text{isen},p} \quad (16)$$

$$W_{p,2} = m_{\text{wl}} \cdot (h_6 - h_5) \quad (17)$$

$$I_{p,2} = (E_6 - E_5) + W_{p,2} \quad (18)$$

$$\eta_{\text{ex},p,2} = (E_6 - E_5) / W_{p,2} \quad (19)$$

• Process from 7 to 8:

$$m_{\text{wl}} \cdot (h_8 - h_7) = m_e \cdot (h_{e,m} - h_{e,out}) \quad (20)$$

$$I_{\text{evap},2} = (E_{e,m} - E_{e,out}) - (E_3 - E_2) \quad (21)$$

$$\eta_{\text{ex,evap},2} = (E_8 - E_7) / (E_{e,m} - E_{e,out}) \quad (22)$$

• Process from 8 to 9:

$$h_9 = h_8 - (h_8 - h_{9s}) \cdot \eta_{\text{isen,expa}} \quad (23)$$

$$W_{\text{expa},2} = m_{\text{wl}} \cdot (h_8 - h_9) \quad (24)$$

$$I_{\text{expa},2} = (E_8 - E_9) - W_{\text{expa},2} \quad (25)$$

$$\eta_{\text{ex,expa},2} = W_{\text{expa},2} / (E_8 - E_9) \quad (26)$$

• Process from 9 to 5:

$$m_c \cdot (h_{11} - h_{10}) = m_{\text{wl}} \cdot (h_9 - h_5) \quad (27)$$

$$I_{\text{cond},2} = (E_9 - E_5) - (E_{11} - E_{10}) \quad (28)$$

$$\eta_{\text{ex,cond},2} = (E_{11} - E_{10}) / (E_9 - E_5) \quad (29)$$

At last definitions of the parameters for the global system performance are described as the following equations.

$$W_{\text{net}} = (W_{\text{expa},1} - W_{p,1}) + (W_{\text{expa},2} - W_{p,2}) \quad (30)$$

$$Q_{\text{in}} = m_e \cdot (h_{e,in} - h_{e,out}) \quad (31)$$

$$\eta_{\text{th,total}} = W_{\text{net}} / Q_{\text{in}} \quad (32)$$

$$E_{\text{in}} = (E_{e,in} - E_{e,out}) + W_{p,1} + W_{p,2} \quad (33)$$

$$E_{\text{out}} = (E_{11} - E_{10}) + W_{\text{expa},1} + W_{\text{expa},2} \quad (34)$$

$$\eta_{\text{th,total}} = W_{\text{net}} / (E_{\text{in}} - E_{\text{out}}) \quad (35)$$

## 4. Results and discussion

Based on the above assumptions and thermodynamic model, performance of TLC-ORC under different evaporating temperature is studied when water, toluene, benzene and cyclohexane is adopted as high temperature working fluid. Evaporating temperature of high temperature cycle is set to be 530K while evaporating temperature of low temperature cycle varies from 343K to 373K.

### 4.1. Energy analysis

Figure 3 shows the change of the net power output and thermal efficiency with  $T_{\text{evap,LT}}$  under different working fluids. As for net power output of TLC-ORC system shown in Figure 3 (a), it is apparently that toluene has the best performance and water performs worst considering the net power output. For any  $T_{\text{evap,HT}}$ , the net power output increases with the rise of  $T_{\text{evap,LT}}$  with a decreasingly smaller rate for all the working fluids. Because the pressure of LTWF at the inlet of expander increases, leading to the increasing of specific net power of LTWF in unit mass increases, which is the dominant factor to affect the net power output. Overall, the maximum net power output of 11.3 kW is achieved by toluene at  $T_{\text{evap,HT}}=530$  K and  $T_{\text{evap,LT}}=373$  K.

As for the change of thermal efficiency with  $T_{\text{evap,LT}}$  under different working fluid, the global trend is quite similar to that of the net power output. Among all the working fluids, Toluene has the largest thermal efficiency at any  $T_{\text{evap,LT}}$ . the thermal efficiency continuously increases with the improvement of  $T_{\text{evap,LT}}$ . The maximum thermal efficiency 24.1% is obtained by Toluene at  $T_{\text{evap,HT}}=530$  K and  $T_{\text{evap,LT}}=373$  K.

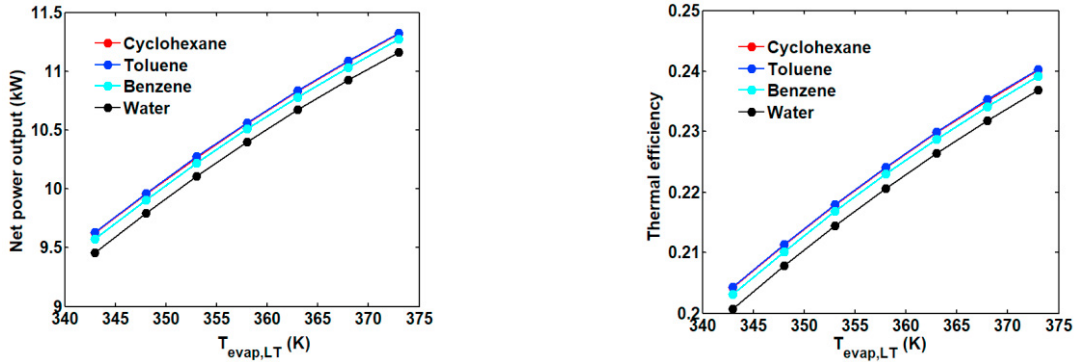

Figure 3. Net power and thermal efficiency under different evaporating temperature and HTWF

4.2. Exergy analysis

Figure 4 shows the variation of exergy efficiency with  $T_{evap,LT}$ . For any kind of working fluid, the exergy efficiency keeps rising with the increase of  $T_{evap,LT}$ , since the temperature of LTWF in evaporators increases with  $T_{evap,LT}$  increasing, leading to the decreasing of temperature different between the working fluid and waste heat in low temperature cycle and exhaust, which is the dominant reason for the decrease of exergy loss and improvement of exergy efficiency. As for the best exergy performance, the maximum exergy efficiency is 63.2% obtained by Toluene at  $T_{evap,HT}=530$  K and  $T_{evap,LT}=373$  K.

Figure 5 represents the exergy destruction and exergy efficiency for components in TLC-ORC system at  $T_{evap,HT}=530$  K and  $T_{evap,LT}=373$  K with Toluene being working fluid, because the exergy efficiency is the maximum in this case. The exergy destruction of each component represents its impact on the system performance. Obviously, evaporator 1 has the largest contribution to the exergy destruction of the whole system, because most of the exergy are input through evaporator1 and. Exergy destruction of expander 1, expander 2 and condenser 1 are the next three components and they have very small difference between each other. The small exergy destruction occurs in pump 1, pump 2 and condenser 1. Therefore, the heat transfer process between the working fluid and exhaust as well as the expanding process are the main factors that influence the exergy performance of whole system.

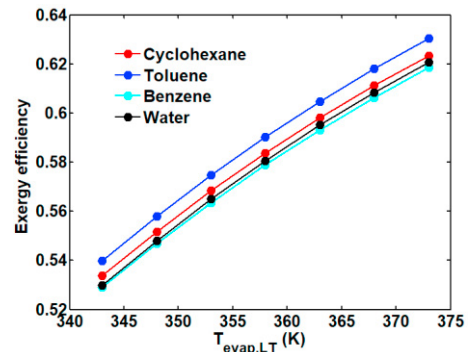

Figure 4. Change of exergy efficiency with  $T_{evap,HT}$  and  $T_{evap,LT}$  under different HTWF.

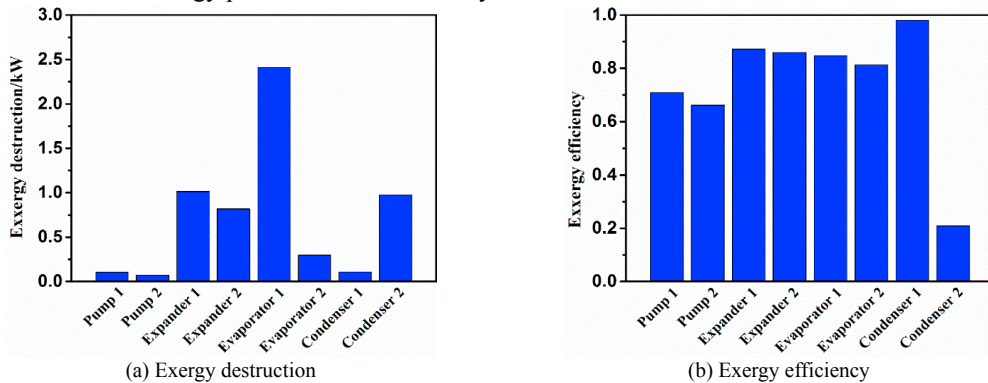

Figure 5. exergy results of Toluene at  $T_{evap,HT}=530$  K and  $T_{evap,LT}=373$  K.

As for exergy efficiency of each component shown in the Figure 5 (b), obviously condenser 2 has the smallest exergy efficiency among all the components which is 20.5%, because the heat absorbed by the cooling water is

completely dissipated without utilization. Thus, utilization of waste heat in the cooling water by other combining waste heat recovering technologies can effectively improve the total efficiency of the whole system. Exergy efficiency of evaporator 1 is slightly larger than that of evaporator 2. That show the superiority of the TLC cycle because in traditional dual-loop organic Rankine cycles evaporator in high temperature cycle is larger than that of evaporator in low temperature cycle.

## 5. Conclusions

Based on the thermal and exergy analysis, main conclusions can be made:

(1) As for net power output, Toluene has the best performance among the studied four high temperature working fluid. At any kind of working fluid, the net power output increases with the rise of  $T_{evap,LT}$ . In terms of thermal efficiency, it has the identical trends to the net power. The maximum net power output 11.3 kW and thermal efficiency 24.2% are both attained by Toluene at  $T_{evap,HT}=530$  K and  $T_{evap,LT}=373$  K.

(2) In regard to exergy analysis, Toluene has the largest exergy efficiency of 63.2% among all the selected working fluids. Among all the components, evaporator 1 has the largest exergy destruction while condenser 1 has the smallest one. However, condenser 2 has the lowest exergy efficiency while condenser 1 has the highest one. The results show us the direction to optimize the heat transfer process between the working fluid and heat source, also the further recovery of waste heat in cooling water is important to boost the overall efficiency of the whole system.

## Acknowledgment

The authors would like to thank the supports from NSFC-RS Joint Project under the grant number No. 5151101443 and IE/151256, from EPSRC through (EP/P001173/1) - Centre for Energy Systems Integration. The first author would like to thank the finical support from UK-China Joint Research and Innovation Partnership fund under the grant number 201703780098. The support from Cao Guang Biao High Tech Talent Fund, Zhejiang University is also highly acknowledged.

## References

- [1] Shu G, Liu P, Tian H, Wang X, Jing D. Operational profile based thermal-economic analysis on an Organic Rankine cycle using for harvesting marine engine's exhaust waste heat. *Energy Conversion and Management*. 2017;146:107-23.
- [2] Quoilin S, Orosz M, Hemond H, Lemort V. Performance and design optimization of a low-cost solar organic Rankine cycle for remote power generation. *Solar Energy*. 2011;85:955-66.
- [3] Tian H, Shu G, Wei H, Liang X, Liu L. Fluids and parameters optimization for the organic Rankine cycles (ORCs) used in exhaust heat recovery of Internal Combustion Engine (ICE). *Energy*. 2012;47:125-36.
- [4] Lee HY, Park SH, Kim KH. Comparative analysis of thermodynamic performance and optimization of organic flash cycle (OFC) and organic Rankine cycle (ORC). *Applied Thermal Engineering*. 2016;100:680-90.
- [5] Fischer J. Comparison of trilateral cycles and organic Rankine cycles. *Energy*. 2011;36:6208-19.
- [6] Yari M, Mehr AS, Zare V, Mahmoudi SMS, Rosen MA. Exergoeconomic comparison of TLC (trilateral Rankine cycle), ORC (organic Rankine cycle) and Kalina cycle using a low grade heat source. *Energy*. 2015;83:712-22.
- [7] Garcia RF, Carril JC, Gomez JR, Gomez MR. Energy and entropy analysis of closed adiabatic expansion based trilateral cycles. *Energy Conversion and Management*. 2016;119:49-59.
- [8] Shu G, Liu L, Tian H, Wei H, Yu G. Parametric and working fluid analysis of a dual-loop organic Rankine cycle (DORC) used in engine waste heat recovery. *Applied Energy*. 2014;113:1188-98.
- [9] Lecompte S, Huisseune H, van den Broek M, Vanslambrouck B, De Paepe M. Review of organic Rankine cycle (ORC) architectures for waste heat recovery. *Renewable and Sustainable Energy Reviews*. 2015;47:448-61.

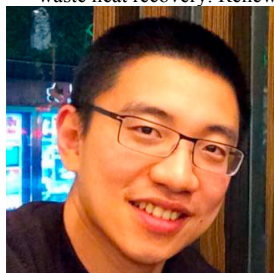

Dr Yiji Lu, born in June 1989, graduated from Shanghai Jiao Tong University in 2011 for his bachelor degree, he conducted his M.Phil. and Ph.D. at Newcastle University in 2012 and 2016. He has published about 40 articles in high quality journals and peer-reviewed conference articles. His research interests include but not limited to advanced waste heat recovery technologies, engine thermal management, chemisorption cycles and expansion machines for power generation system. He has been regularly invited to review the manuscripts for the scientific journals including *Applied Energy* (IF 7.181), *Applied Thermal Engineering* (IF 3.356), *Energy* (IF 4.520), and *Energy for Sustainable Development* (IF 2.790).